

ORIGINAL INSTRUCTIONS
NP Series Gasoline Engine

OPERATOR'S MANUAL



Read this manual carefully before operation.
This manual includes important guidance for safety operation.

This Manual contains important safety information and instructions for operating this engine. **PLEASE READ THIS MANUAL CAREFULLY.** Failure to do so could result in property damage and/or personal INJURY/DEATH.
Provide this manual to any operator of this engine. This manual should be considered as a permanent part of your engine and should remain with it when you sell it.
The pictures and figures in the manual shall be only for reference and perhaps there will be difference between pictures & figures and physical products.
All information in this publication is based on the latest product information available at the time of printing. We reserve the right to change, alter and/or improve the product and this document at any time without notice and without incurring any obligation.
Write down the engine's serial number and purchase information. Keep this manual and the receipt for future reference.

Model:

Serial number:

Date of purchase:

Contents

I. Operator Safety

1. Safety rules

II. Features and Controls

III. Operating

1. Operating checklist
2. Starting the engine
3. Stopping the engine

IV. Maintenance

1. Maintenance schedule
2. General maintenance
3. Idle speed
4. Adjustment

V. Trouble-shooting

VI. Storage and Transportation

VII. Specification

1. Specification Parameter Table
2. Crankcase Cover Installation Dimension

I. Operator Safety

1. Safety rules



Pay attention to this safety alert symbol. Obey all safety messages that follow this symbol to avoid possible property damage, INJURY or DEATH.

Each safety message is preceded by a safety alert symbol and one of three words, DANGER, WARNING, or CAUTION.

⚠️ DANGER

Indicates a hazardous situation which, if not strictly complied with, will result in substantial property damage, serious injury or DEATH.

⚠️ WARNING

Indicates a hazardous situation which, if not strictly complied with, may result in property damage, serious injury or DEATH.

⚠️ CAUTION

Indicates a hazardous situation which, if not strictly complied with, could result in property damage, or injury.



⚠️ WARNING

READ THIS MANUAL COMPLETELY BEFORE OPERATING.

DO NOT operate this engine until you have read ALL safety, operation, and maintenance instructions listed in this manual.

Failure to follow the instructions may result in property damage, INJURY or DEATH.

The warnings and precautions discussed in this manual cannot cover all possible conditions and situations that may occur. It must be understood by the operator that common sense and caution are factors which cannot be built into this product, but must be supplied by the operator.

⚠️ WARNING

This engine is intended for residential consumer use only. Do not use the engine for a purpose for which it is not intended.

⚠️ DANGER

Do not tamper with the engine governed speed. High operating speeds are dangerous and increase the risk of personal injury or damage to the equipment. Operating at low speeds with heavy load may shorten the engine's life.

⚠️ WARNING

Before each use, check for loose or damaged parts, signs of oil or fuel leaks, and any other condition that may affect proper operation. Repair or replace all damaged or defective parts immediately.

Locate all operating controls and safety labels.

Keep all safety guards in place and in proper working order at all times.

DO NOT allow any material to block the cooling slots.

DO NOT allow children or untrained persons to operate the engine.

DO NOT run the engine unattended. Turn off the Engine before leaving the area.



⚠️ WARNING

KICKBACK

Rapid retraction of the starter cord will pull hand and arm towards the engine faster than you can let go.

Unintentional startup can result in entanglement, traumatic amputation or laceration. Broken bones, fractures, bruises or sprains could result.



⚠️ DANGER

TOXIC FUMES

The exhaust of the engine contains carbon monoxide, an odorless, colorless, poison gas. Using engine indoors CAN KILL YOU!

NEVER use inside any building or any kind of enclosure, EVEN IF doors and windows are open.

Place the engine in a well-ventilated area and carefully consider wind and air currents when positioning the engine.



⚠️ WARNING

FIRE

Operation of this engine may create sparks that can start fires around dry vegetation.

This engine may not be equipped with a spark arresting muffler. If the engine will be used around flammable materials, or on land covered with materials such as agricultural crops, forest, brush, grass, or other similar items, then an approved spark arrester must be installed.

In some area, a spark arrester is required by law. Please contact local fire agencies for laws or regulations relating to fire prevention requirements.



⚠️ DANGER

Moving Parts

Moving parts can cause severe injury. Keep hands and feet away. DO NOT operate engine with covers, shrouds, or guards removed. DO NOT wear loose-fitting clothing, dangling drawstrings or items that could become caught. Tie up long hair and remove jewelry. NEVER place fingers, hands, or body near the engine when it is running.

⚠️ WARNING

Read the instructions provided with the equipment that powered by this engine for any additional safety rules that should be observed in conjunction with engine startup, shutdown, operation, or protective apparel that may be needed to operate the equipment.



⚠️ WARNING

HOT SURFACE

Running engines produce heat. Severe burns can occur on contact.

DO NOT touch engine while operating or just after stopping. Avoid contact with hot exhaust gases.

Maintain at least three feet of clearance on all sides to ensure adequate cooling.

Combustible material can catch fire on contact. Maintain at least five feet of clearance from combustible materials.



⚠️ DANGER

FIRE OR EXPLOSION

Gasoline is highly flammable and extremely explosive.

Fire or explosion can cause severe burns or death.

Keep flammable items away while handling gasoline.

Fill fuel tank outdoors and in a well-ventilated area With the engine stopped.

Always wipe off spilled fuel and wait until the fuel has dried before starting the engine.

DO NOT operate the engine with known leaks in the fuel system.

Use proper fuel storage and handling procedures. DO NOT store fuel or other flammable materials nearby.

Empty the fuel tank before storing or transporting this engine. Keep fire extinguisher handy and be prepared if a fire starts.

II. Feature and Control

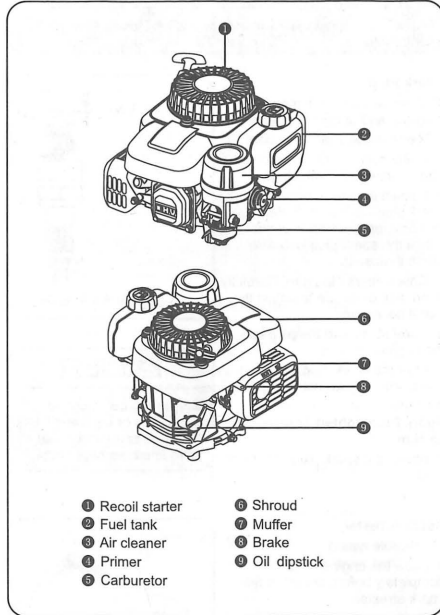

-4-

III. Operating

1. Operating checklist

1 Operation Location

Only use OUTSIDE and place the engine in a well-ventilated area and carefully consider wind and air currents.

Place the engine on level surface before any operation.

Allow two feet clearance on all side of the engine while operating it outdoors.



DANGER

TOXIC FUMES

The exhaust of the engine contains carbon monoxide, an odorless, colorless, poison gas. Using engine indoors CAN KILL YOU!

NEVER use inside any building or any kind of enclosure, EVEN IF doors and windows are open.

High altitude

The engine may require a high altitude carburetor kit to ensure correct operation at high altitude. Consult your local dealer for high altitude kit information if you always operate your engine at altitudes above 5,000 feet (1,500 meters).

CAUTION

Even with carburetor modification, engine horsepower will decrease about 3.5% for each 1,000 feet (300 meters) increase in altitude. The effect of altitude on horsepower will be greater than this if no carburetor modification is made.

CAUTION

Operation the engine at altitude below 5,000 feet (1,500 meters) with modified carburetor may cause the engine to overheat and result in serious engine damage.

2 Operating Condition

Check for loose or damaged parts, signs of oil or fuel leaks, and any other condition that may affect proper operation. Repair or replace all damaged or defective parts immediately.

WARNING

Failing to correct problem(s) before operation could result in property damage, serious injury or DEATH.

Remove any excessive dirt or debris, especially around the muffler and recoil starter.

Refer to operating instructions of equipment that this engine powers. Do not operate this engine exceeding maximum angle of

-5-

operation; see specification table. Engine damage could result from insufficient lubrication.

3 Engine Oil

Place the engine on a level surface with engine stopped.

Remove the dipstick and wipe it clean.

Reinstall dipstick into tube; rest on oil fill neck, DO NOT thread cap into tube.

Remove the dipstick again and check oil level. Level should be at top of indicator on dipstick.

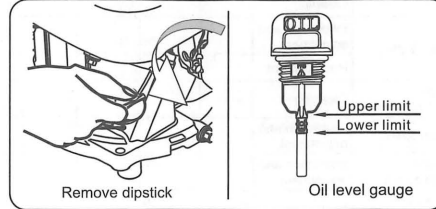

Fill to the upper limit (marked with "H") of the dipstick with the recommended oil if the oil level is low. Reinstall and fully tighten the dipstick.

Refer to **add oil** instruction in **MAINTENANCE** section for more information.

Oil capacity (rated): see parameters.

WARNING

The engine is not filled with oil at the factory. Any attempt to crank or start the engine before it has been properly filled with the recommended type and amount of oil may result in engine damage and void your warranty.

WARNING

Oil is a major factor affecting performance and service life. Use 4-stroke automotive detergent oil recommended in the **MAINTENANCE** section of this manual.

4 Engine Fuel

With the engine stopped, check the fuel level gauge. Refill the fuel tank if necessary.

CAUTION

Pressure can build up in the fuel tank. Allow the engine to cool for at least two minutes before removing fuel cap. Loosen the fuel cap slowly to relieve any pressure in the tank.

-6-

Use clean, fresh, regular unleaded gasoline.

DO NOT mix oil with gasoline.

Be sure not to fill above the upper limit mark. Always allow room for fuel expansion.

Fuel capacity (rated): see parameters.

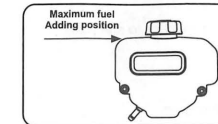

DANGER

Do not fill the fuel tank above the upper limit. Over fill will result in engine die or damage the carbon canister (if equipped) and void your warranty.



WARNING

Fire or Explosion

Gasoline is highly flammable and extremely explosive.

Fire or explosion can cause severe burns or death.

Keep flammable items away while handling gasoline.

Fill fuel tank outdoors and in a well-ventilated area with engine stopped.

Always wipe off spilled fuel and wait until the fuel has dried before starting the engine.

DO NOT operate the engine with known leaks in the fuel system.

Use proper fuel storage and handling procedures. DO NOT store fuel or other flammable materials nearby.

Empty the fuel tank before storing or transporting this engine. Keep fire extinguisher handy and be prepared if a fire starts.

NEVER use engine or carburetor cleaner products in the fuel tank or permanent damage may occur.

It is important to prevent gum deposits from forming in essential fuel system parts, such as the carburetor, fuel filter, fuel hose or tank during storage. Also, experience indicates that alcohol-blended fuels (called gasohol, ethanol or methanol) can attract moisture, which leads to separation and formation of acids during storage.

Acidic fuel can damage the fuel system of an engine while in storage. Be sure to review the instructions given in "Storage" chapter.

Gasoline/Alcohol Blends: up to 10% alcohol, 90% unleaded gasoline by volume is approved as a fuel. Other gasoline/alcohol blends are not approved. Effects of old, stale or contaminated fuel are not warrantable.

CAUTION

To minimize gum deposits in your fuel system and to insure easy starting, do not use gasoline left over from the previous season.

-7-



CHONGQING ZONGSHEN GENERAL POWER MACHINE CO., LTD.

Address: Zongshen Industry Zone, Banan District, Chongqing, 400054, China

Phone: 0086-23-66372525

Hot Line: 0086-4001696444 0086-23-66372519 0086-23-66372096

http://www.zongshenpower.com

1563#

5 Equipment check

Check the equipment powered by this engine. Review the instructions provided by the equipment manufacturer for any precautions and procedures that should be followed before starting the engine.

⚠ WARNING

This engine is designed and manufactured for specific applications. Do not attempt to modify the equipment or use it for any application for which it was not designed. If you have questions about specific application, ask your local dealer.

2. Starting the Engine

1

Perform operating checklist.

2

Before starting the cold engine, press the primer pump with hand for three times (the primer pump may not be pressed after the gasoline engine is running for more than 6 min); If the engine is in the hand choke state, please close the hand choke (the hand choke can be opened after the engine is running for ≥ 3 s).

3

Manual starting

⚠ WARNING

Check starter cord conditions before operating. Have it replaced immediately by local authorized dealer if cord is frayed.

When starting engine, grasp the recoil starter handle and pull slowly until resistance is felt. Then pull rapidly to avoid kickback.



⚠ WARNING

KICKBACK
Rapid retraction of the starter cord will pull hand and arm towards the engine faster than you can let go. Unintentional startup can result in entanglement, traumatic amputation or laceration. Broken bones, fractures, bruises or sprains could result.

4

When the engine is working, please use it in the scope with the inclination of 20° in all directions.

-8-

3. Stopping the Engine

1

If possible, remove the load(s) on the engine.

2

Allow the engine run at no load for a few minutes to stabilize internal temperature of the engine.

3

Please take back the brake to stop the engine.

4

Turn the fuel switch, if any, to the OFF position.

IV. Maintenance

It is the owner's/operator's responsibility to complete all scheduled maintenance in a timely manner. Correct any issue before operating the engine. Always follow the inspection and maintenance recommendations and schedules in this manual.

Before servicing the engine, **stop the engine**, disconnect all electric devices and battery (if equipped) and allow the engine to cool down.

⚠ WARNING

Improper maintenance or failure to correct a problem before operation can cause a malfunction and result in property damage, serious injury or DEATH. Improper maintenance will void your warranty.



⚠ DANGER

Accidental starts can cause severe injury or death. Remove and ground spark plug wire before performing any service.

⚠ CAUTION

The filter element may contain PAHs, PAHs are harmful for your health. Please wear gloves for protection during air filter maintenance.

1. Maintenance schedule

Follow the service intervals indicated in the chart below. Service your engine more frequently when operating in adverse conditions. Contact your local service dealer for your engine or engine maintenance needs.

-9-

		Each time before use	10 hours or the first month ²	50 hours or every three months ²	100 hours or every six months ²
Engine oil	Inspection	√			
	Replacement		√		√
Air filter	Inspection	√			
	Cleaning			√ ³	
Spark plug	Inspection and adjustment				√
	Replacement				
Spark extinguisher ¹	Cleaning				√
Idle speed	Inspection and adjustment				
Valve clearance	Inspection and adjustment				
Carbon canister ¹	Inspection	Every two years ⁴			
Low permeability oil tube ¹	Inspection	Every two years ⁴			
Oil tube	Inspection	Every two years ⁴			

Note1: Applicable types (if available).

Note2: Before each season and after then (whichever comes first).

Note3: Service more frequently under severe, dusty, dirty conditions.

Note4: To be performed by knowledgeable, experienced owners or the authorized dealer.

2. General maintenance

Engine oil

SAW 10W-30 is recommended for general, all-temperature use. Other viscosities shown in the chart may be used when the average temperature in your area is within the indicated range.

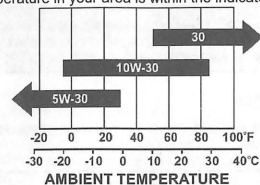

Oil capacity (rated): see parameters.

Add oil

1. Place the engine on a level surface.
2. Remove the dipstick and wipe it clean.
3. Add recommended oil to the upper limit.

-10-

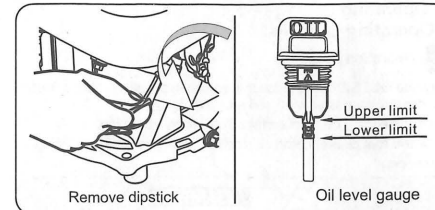

⚠ CAUTION

Oil level check

Reinstall dipstick into tube; rest on oil fill neck, DO NOT thread cap into tube.

4. Fully tighten the dipstick.

Change oil

⚠ CAUTION

Change oil when the engine is warm from operation.

1. Place the engine on a level surface.
2. Clean area around dipstick and drain plug.
3. Remove oil dipstick.
4. Remove the oil drain plug and allow the oil to drain completely.
5. Replace and fully tighten the drain plug.
6. Add recommended oil to the upper limit (see add oil instruction above).
7. Reinstall and fully tighten the dipstick.
8. Disposal of used oil at an approved waste management facility.

⚠ WARNING

The engine is not filled with oil at the factory. Any operation before it has been properly filled with the recommended type and amount of oil may result in engine damage and void your warranty.

Air Filter

1. Screw out the lock nut and remove the air filter cover.
2. Take down the filter element.
3. Clear away internal impurities.
4. Place the filter in the assembly.
5. Reinstall the air filter cover and snap in place.



-11-

⚠ WARNING

DO NOT run the engine without the air filter, serious danger can result.

Spark Plug

1. Clean any dirt from the spark plug cap and spark plug base.
2. Remove the spark plug cap.
3. Using socket wrench to loose and remove the spark plug.
4. Inspect the spark plug and spark plug washer, if it's damaged or worn, replace with new one. Clean the spark plug with wire brush if reuse it.
5. Check spark plug gap. Carefully bend side electrode to adjust the gap if necessary.
6. Carefully thread the plug into the engine by hand.
7. After the spark plug is seated, use spark plug wrench to tighten the plug.
8. Attach the spark plug wire to the plug.

0.6mm - 0.8mm



⚠ WARNING

Only use recommended spark plug or equivalent. DO NOT use spark plugs that have improper heat range.

Spark Arrester (Applicable types)

1. Allow the engine to cool completely before servicing the spark arrester.
2. Remove the two screws holding the cover plate which retains the end of the spark arrester to the muffler.
3. Remove the spark arrester screen.
4. Carefully remove the carbon deposits from the spark arrester screen with a wire brush.
5. Replace the spark arrester if it is damaged.
6. Reinstall the spark arrester in the muffler and attach with the two screws.

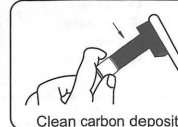

3. Idling Speed

The Idle speed has been pre-set at the factory and should rarely require readjustment. Consult your local authorized dealer for such needs.

-12-

⚠ WARNING

Unauthorized adjustment will damage your engine and/or your electrical devices and void your warranty.

4. Adjustment

There has no other service and/or adjustment need for your engine. Unapproved adjustments or tampering can damage your engine and your electrical devices and will void your warranty. Contact your local dealer for such needs.

⚠ WARNING

Tampering with the factory set governor will damage your engine and void your warranty.

V. Trouble analysis and trouble-shooting

Phenomenon	Problems	Solutions
Engine Cannot be started	The engine brake is in the braking state (the engine flameout switch is in the flameout state)	Draw the engine brake away from the braking state (the engine flameout switch is in the off state)
	There is no fuel	Fill tank per instructions in this manual.
	Inadequate engine oil.	Check oil level. The engine cannot be started unless the oil level is above the prescribed lower limit.
	There is no ignition	Remove the spark plug cap. Clean any dirt from around the plug base, then remove the spark plug. Install the spark plug in the plug cap. Grounding the electrode to any engine ground, pull the recoil starter to see if sparks jump across the gap. If there is no spark, replace the plug. Reinstall the plug and start engine according to instructions in this manual. Consult Customer Service if necessary.

-13-

VI. Storage and transportation**Storage**

DO NOT mix oil with gasoline. The engine should be started at least once every 2 weeks and allowed to run for at least 20 minutes. Follow the instructions below for longer term storage if the engine will be out of service for 2 months or more.

**⚠ DANGER****Fire or Explosion**

Gasoline is highly flammable and extremely explosive. Empty the fuel tank and shut off fuel valve before storing or transporting this engine.

1. Change oil while engine is still warm from operation.
2. Allow the engine to cool down completely.
3. Drain all fuel completely from the fuel tank, fuel hose and carburetor.
4. Remove the spark plug and pour about 1 oz. of engine oil into the cylinder. Reinstall the spark plug. Crank engine slowly to distribute oil and lubricate cylinder.
5. Clean the engine according to the instructions in the Maintenance section.
6. Store the unit in a clean and dry area out of direct sunlight.

Transportation

To prevent fuel spillage when transporting or during temporary storage, the engine should be secured upright in its normal operating position, with the engine switch OFF. The fuel switch should be turned OFF.

⚠ WARNING**When transporting:**

Do not over fill the tank. Avoid a place exposed to direct sunlight when putting the engine on a vehicle. If the engine is left in an enclosed vehicle for many hours, high temperature inside the vehicle could cause fuel to vaporize resulting in a possible explosion. Do not drive on a rough road for an extended period with the engine on board. If you must transport the engine on a rough road, drain the fuel from the engine beforehand.

⚠ CAUTION

Take care not to drop or strike the engine when transporting. Do not place heavy objects on the engine.

-14-

VII. Specifications**1. Specifications Parameters Table**

Category	Item	NP80	NP100	
Main structure parameters	Air valve arrangement	Overhead valve	Overhead valve	
	Number of air cylinders	1	1	
	Air cylinder diameter(mm)	51	57	
	Piston stroke(mm)	38.8	38.8	
	Total displacement(cm ³)	79	99	
	Compression ratio	7.6:1	8.2:1	
	Rated power(kW/min ⁻¹)	1.5/3600	1.65/3600	
	Direction of rotation	Anticlockwise (From the PTO end direction)		
	Ignition advance angle(°)	25°±2°	25°±2°	
	Valve clearance	Admission valve clearance (mm)	0.10-0.15	0.10-0.15
		Emission valve clearance (mm)	0.15-0.20	0.15-0.20
	Spark gap(mm)	0.6-0.8	0.6-0.8	
	Fuel and oil	Lubricating oil brand	SAE 10W-30	SAE 10W-30
Fuel supplier		Carburetor oil supply	Carburetor oil supply	
Fuel capacity(L)		0.75	0.75	
Demission and mass	Oil capacity(L)	0.4	0.4	
	Demission(mm) (Length×Width×Height)	295×295×240	295×295×240	
	Net mass(kg)	6.8	6.8	

-15-

Category	Item	NP130	NP150	NP160	
Main structure parameters	Air valve arrangement	Overhead valve			
	Number of air cylinders	1	1	1	
	Air cylinder diameter(mm)	61	65	67	
	Piston stroke(mm)	45	45	45	
	Total displacement(cm ³)	132	149	159	
	Compression ratio	8.1:1	8.3:1	8.5:1	
	Rated power(kW/min ⁻¹)	2.2/3600	2.5/3600	2.7/3600	
	Direction of rotation	Anticlockwise (From the PTO end direction)			
	Ignition advance angle(°)	18°±2°			
	Valve clearance	Admission valve clearance (mm)	0.10-0.15		
		Emission valve clearance (mm)	0.15-0.20		
	Spark gap(mm)	0.6-0.8			
	Fuel and oil	Lubricating oil brand	SAE 10W-30		
Fuel supplier		Carburetor oil supply			
Fuel capacity(L)		0.75			
Demission and mass	Oil capacity(L)	0.4			
	Demission(mm) (Length×Width×Height)	307×295×240			
	Net mass(kg)	7.2			

Notes: The gasoline engine with different specifications and configurations may have different parameters and may change at any time without notice.

-16-

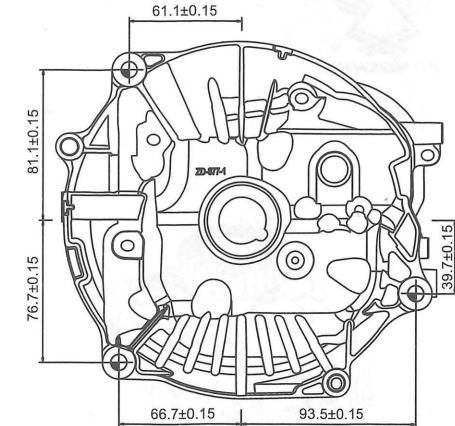
2. Case Cover Installation Dimension

-17-