

AUTOTALLI

KÄYTTÖOHJE

MALLIT SNCG-A1, SNCG-C1, SNCG-C2

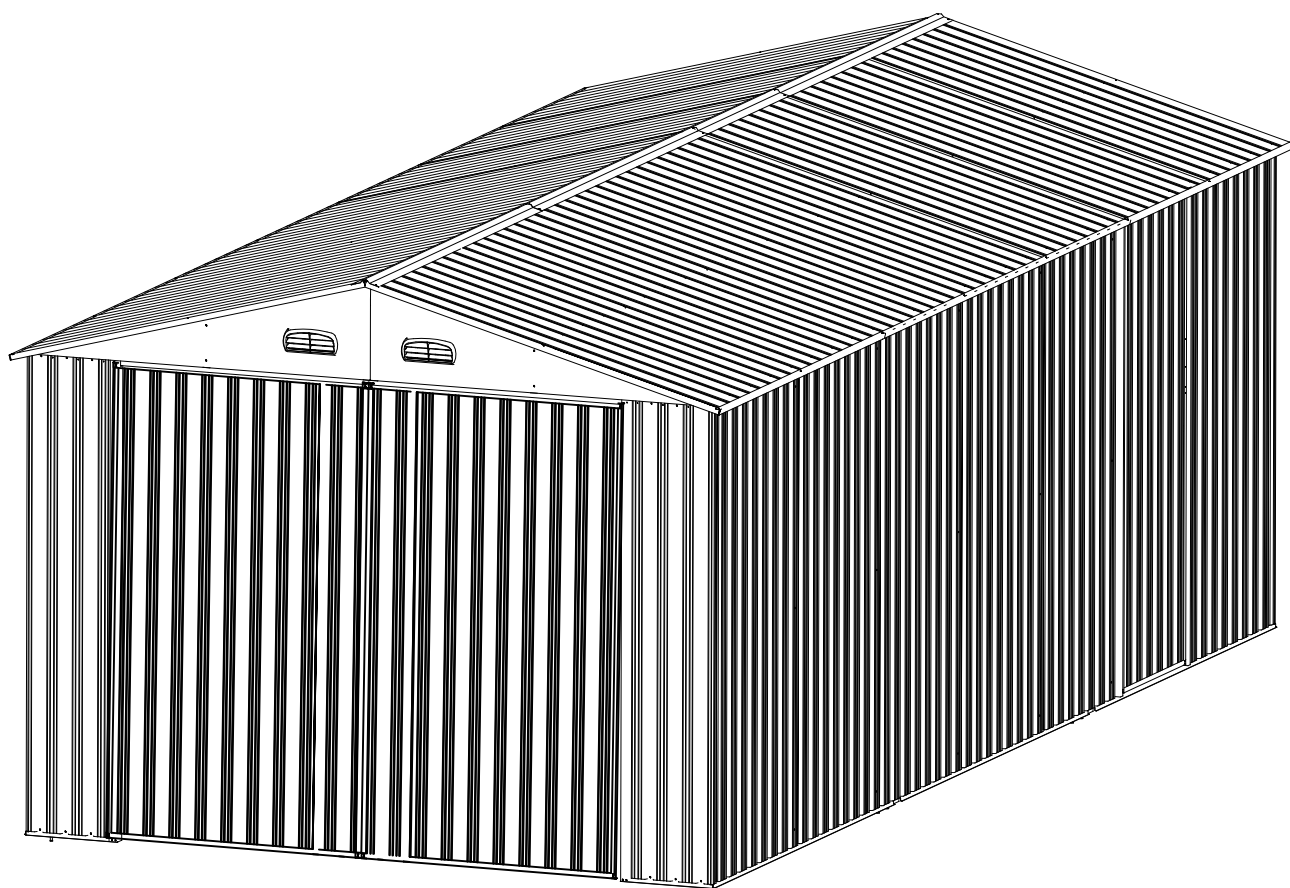

ENNEN KUIN ALOITAT

KÄYTTÖOHJE

Ennen asennusta on tärkeää, että otat yhteyttä paikallisiin viranomaisiin selvittääksesi, tarvitsetko rakennusluvan. Lue ja sisäistä tämä käyttöohje. Ohjeen tiedot ja neuvot tekevät rakentamisesta helpompaa ja mukavampaa.

Kokoamisohjeet

Näistä ohjeista löydät kaiken tarvittavan tiedon autotallin kokoamiseksi. Lue kaikki ohjeet ennen aloittamista. Tee kokoaminen askel askeleelta ohjeiden mukaisesti. Huomaa: **kokoamiseen menee kahdelta henkilöltä yksi kokonainen päivä.**

Osat

Varmista, että sinulla on kaikki tarvittavat osat. Lajittele osat numeroittain alla olevan luettelon mukaisesti. Tutustu osiin ja kiinnikkeisiin etukäteen kokoamisen helpottamiseksi. Löydät ne pahvilaatikon sisältä. Huomaa, että toimituksessa on ylimääräisiä kiinnikkeitä.

TARVITTAVAT TYÖKALUT

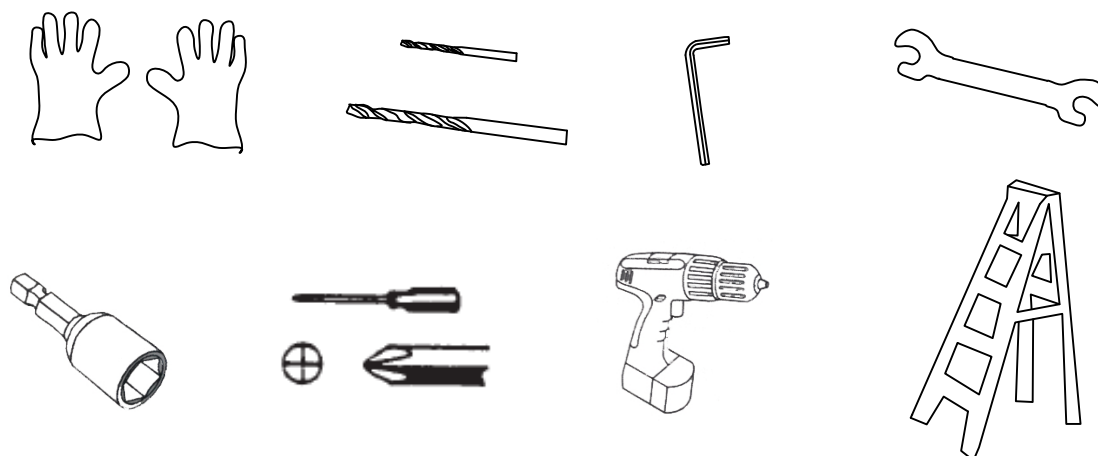

Käytä työkaluneita käsitellessäsi peltilevyjä

ENNAKOI



Asennukseen menee kahdelta henkilöltä kokonainen päivä.

Tarkkaile säätä

Varmista, että asennuspäivä on kuiva ja tyyni. ÄLÄ yritä koota tallia tuulisena päivänä, se voi johtaa peltien vahingoittumiseen tai henkilövahinkoihin. Ole varovainen märällä tai mutaisella maalla.





























Yhteispeliä



























On suositeltavaa, että mahdollisuuksien mukaan kokoat tallin kaksin tai useamman henkilön avustuksella. Näin yksi henkilö voi asetella osat ja pellit toisen kiinnittäessä niitä.





























OSALUETTELO SNCG-A1

PART	NO.	Qty.	PART	NO.	Qty.	PART	NO.	Qty.
	1	2		18	2		P6L	1
	2	2		19	3		P6R	1
	3	2		20	1		P4L	8
	3L	1		21L	2		P4R	6
	3R	1		21R	2		D1	1
	4L	1		22	4		B1	2
	4R	1		23	2		B2	2
	5L	1		24	2		B3	4
	5R	1		25L	1		L1	16
	6L	2		25R	1		J1	4
	6R	2		26	2		J2	4
	7	1		27	1		B5	1
	8	2		28	1		B6	3
	9	2		29	2		H1	1
	10L	1		30	1		GC	4
	10R	1		31	4		GE	2
	11	2		32	4		GF	4
	12L	2		33	4		F1	
	12R	4		34	2		F2	
	12	4		P1	10		F5	
	13	4		P2	2		F6	
	14	4		P3	2		Rolling door motor	1
	15	2		P4	1		Door rails L	1
	16	2		P5	1		Door rails R	1
	17	2		P6	1		Cover	8
	F3			F4			F7	
	7L	1		15L	2		GS	4
	7R	1		15R	2			































OSALUETTELO SNCG-C1































PART	NO.	Qty.
	1	2
	2	2
	3	2
	3L	1
	3R	1
	4L	1
	4R	1
	5L	1
	5R	1
	6L	2
	6R	2
	7	1
	8	2
	9	2
	10L	1
	10R	1
	11	2
	12L	2
	12R	4
	12	4
	13	4
	14	4
	15	2
	16	2
	17	2
	F3	
	27L	1
	25	4
	7L	1
	7R	1































PART	NO.	Qty.
	18	2
	19	3
	20	1
	21L	2
	21R	2
	22	4
	23	2
	24	2
	25L	1
	25R	1
	26	2
	27	1
	28	1
	29	2
	30	1
	31	4
	32	4
	33	4
	34	2
	P1	10
	P2	2
	P3	2
	P4	1
	P5	1
	P6	1
	F4	
	28L	1
	H2	1
	15L	2
	15R	2

PART	NO.	Qty.
	P6L	1
	P6R	1
	P4L	8
	P4R	6
	D1	1
	B1	2
	B2	2
	B3	4
	L1	16
	J1	4
	J2	4
	B5	3
	B6	9
	H1	3
	GC	4
	GE	2
	GF	4
	F1	
	F2	
	F5	
	D2	2
	D3	2
	24L	4
	27R	1
	28R	1
	35	2
	F7	
	F8	
	GS	4

OSALUETTELO SNCG-C2

PART	NO.	Qty.
	1	2
	2	2
	3	2
	3L	1
	3R	1
	4L	1
	4R	1
	5L	1
	5R	1
	6L	2
	6R	2
	7	1
	8	2
	9	2
	10L	1
	10R	1
	11	2
	12L	2
	12R	4
	12	4
	13	4
	14	4
	15L	2
	16L	1
	16R	1
	F1	
	F2	
	F7	
	27L	1
	F8	
	15R	2

PART	NO.	Qty.
	17	2
	18	2
	19	2
	20	1
	21L	2
	21R	2
	22	4
	23	2
	24	2
	25L	1
	25R	1
	26	2
	27	1
	28	1
	29	2
	30	1
	31	4
	32	4
	33	4
	34	2
	P1	7
	P2	3
	P3	2
	P4	1
	P5	1
	F3	
	F4	
	35	2
	28L	1
	7L	1
	7R	1

PART	NO.	Qty.
	P6	1
	P6L	1
	P6R	1
	P4L	4
	P4R	4
	P7	1
	P8	1
	P9	1
	P10	1
	D1	1
	B1	2
	B2	2
	B3	4
	L1	16
	J1	4
	J2	4
	B5	3
	B6	9
	H1	3
	GC	4
	GE	2
	GF	4
	F5	
	D2	2
	D3	2
	24L	4
	27R	1
	28R	1
	25	4
	H2	1
	GS	4

ENNAKOI

Paikan valinta

- Vältä puunkoksien alle asentamista. Tällöin tallia on puhdistettava säännöllisesti, ja katkeavat oksat muodostavat vaaran.
- Toisaalta, lähellä olevat pienemmät puut, pensaat ja aidat suojaavat tallia tuulelta.

Paikan valmistelu

Asennuspaikan on oltava vaakasuora kauttaaltaan. Varmista asia vesivaa'alla. Perusta voidaan tehdä kyllästetystä puusta tai sementistä, jottei kosteus tunkeudu talliin. **Tallia ei ole suunniteltu rakennettavaksi suoraan nurmikolle.** Maa muuttuu myös kuraiseksi sateisina päivinä.

Jos tallille rakennetaan betonialusta, on tärkeää tehdä kaadot reunojen suuntaan, jotta vesi valuu pois. Anna sementin tai betonin kuivua kunnolla ennen tallin rakentamista.

Perusta voidaan myös rakentaa tiilistä tai harkoista, tai sitten talli voidaan rakentaa betonialustan päälle. Tiilet tai harkot pitää sementoida tukevalle ja vaakasuoralle betonille, ja tallin runko on porattava ja ruuvattava perustaan kiinni.

TÄRKEÄÄ

Kokoa talli kaksin: on paljon helpompaa, kun toinen pitää kiinni osista, ojentaa työkaluja jne. Joissakin vaiheissa on oltava vähintään kaksi henkilöä (rakenteiden nostamisessa).

Älä kiirehdi. Kiire johtaa yleensä vain virheisiin sekä niiden myöhempiin korjauksiin. Jos et ole ennen pystyttänyt tallia, siihen voi mennä suurin osa päivästä.

- Pidä oikeat työkalut saatavillasi.
- Pukeudu "Työkalut"-kohdassa kuvatulla tavalla.

On suositeltavaa ottaa kaikki osat esille ja varmistaa, että kaikki on mukana ennen työn aloittamista. Asettele osat muovin tai kankaan päälle, jos osat ovat vaarassa naarmuuntua.

Kiristä kaikki mutterit kunnolla. Varmista, että runko on neliön muotoinen ja tarkista pystysuoruus vesivaa'alla.

TARKAT ULKOMITAT SNCG-A1 (SNCG-C1)

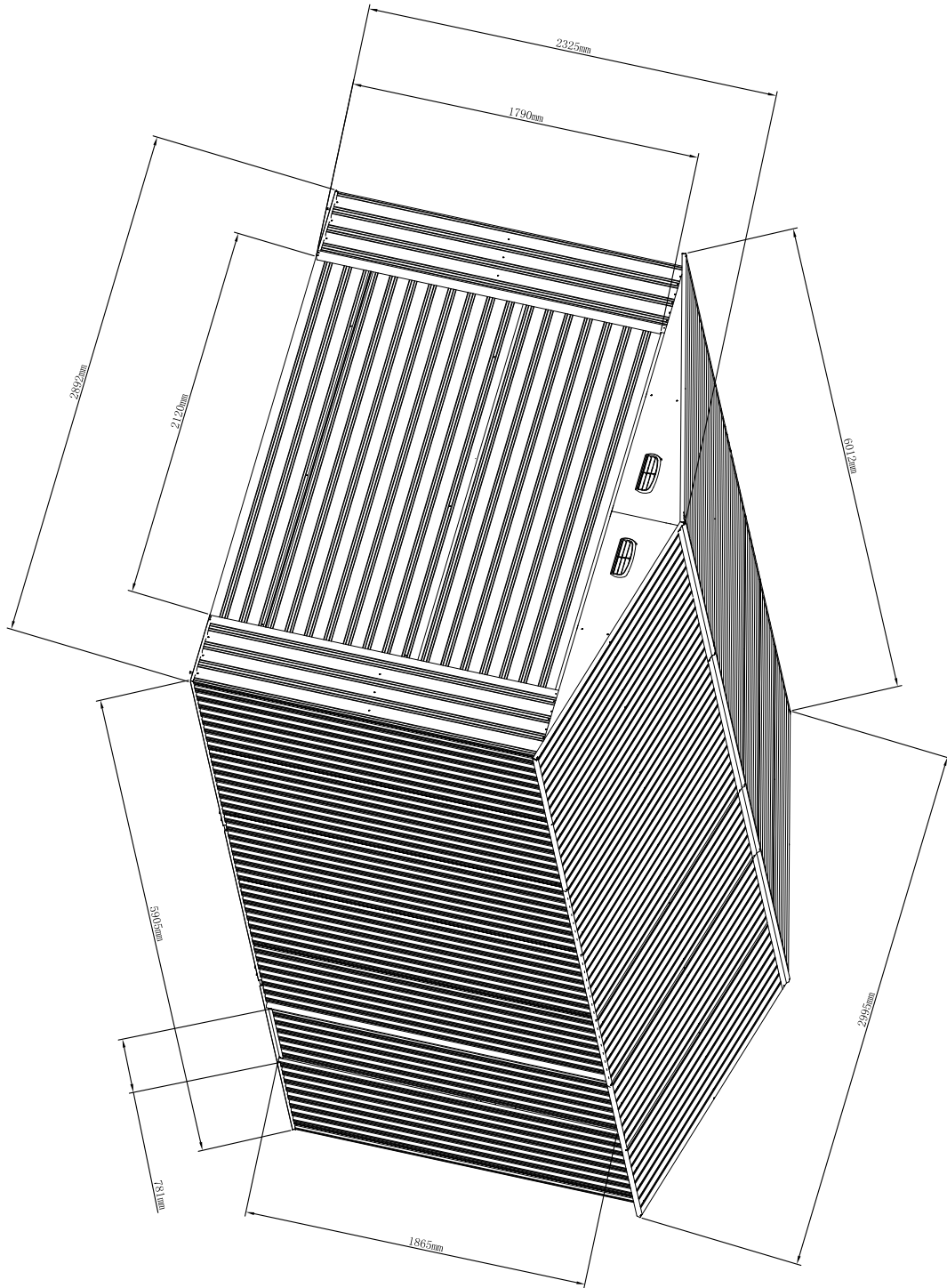

TARKAT ULKOMITAT SNCG-C2

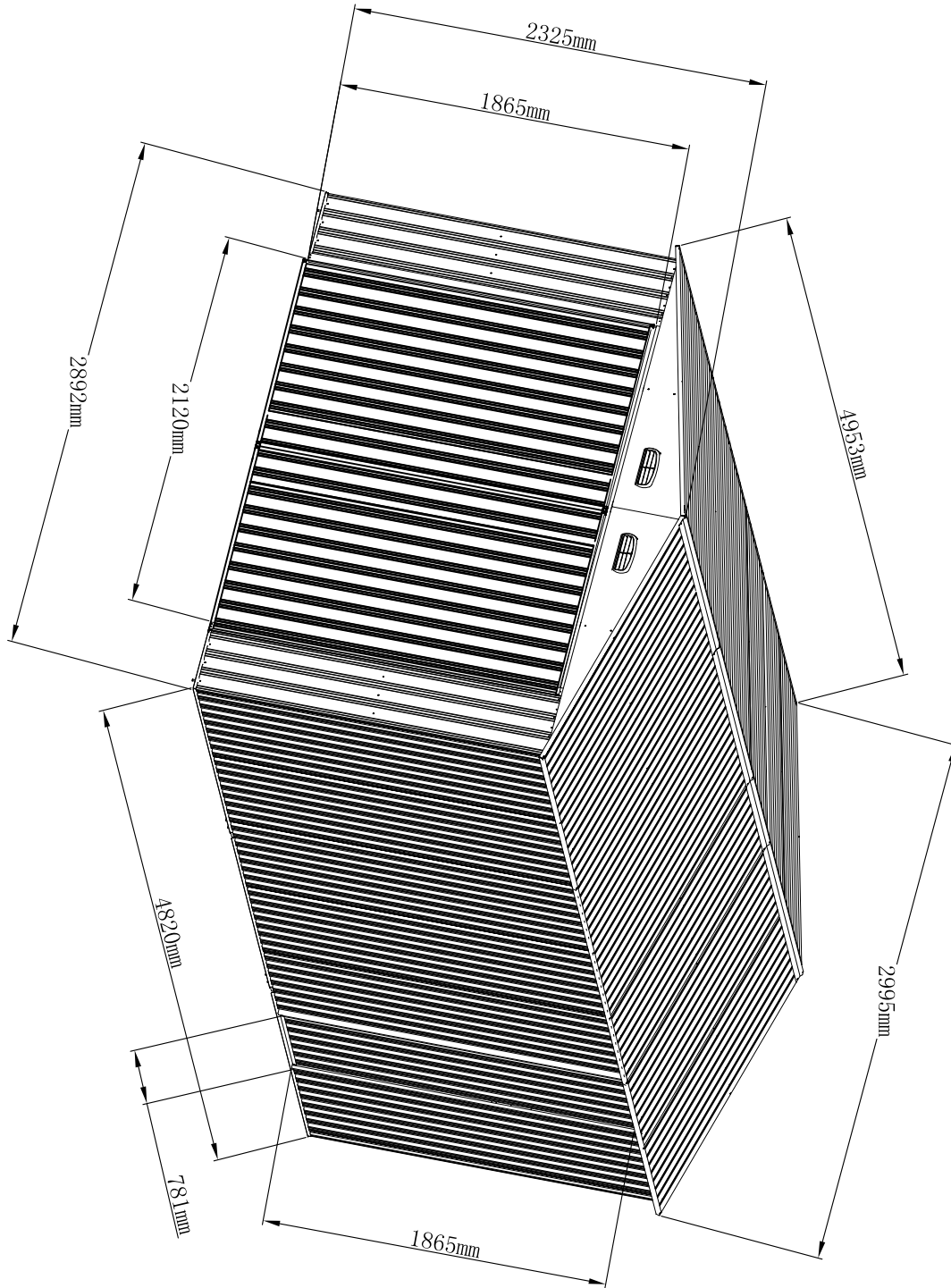

YLEINEN ULKOASUSNCG-A1

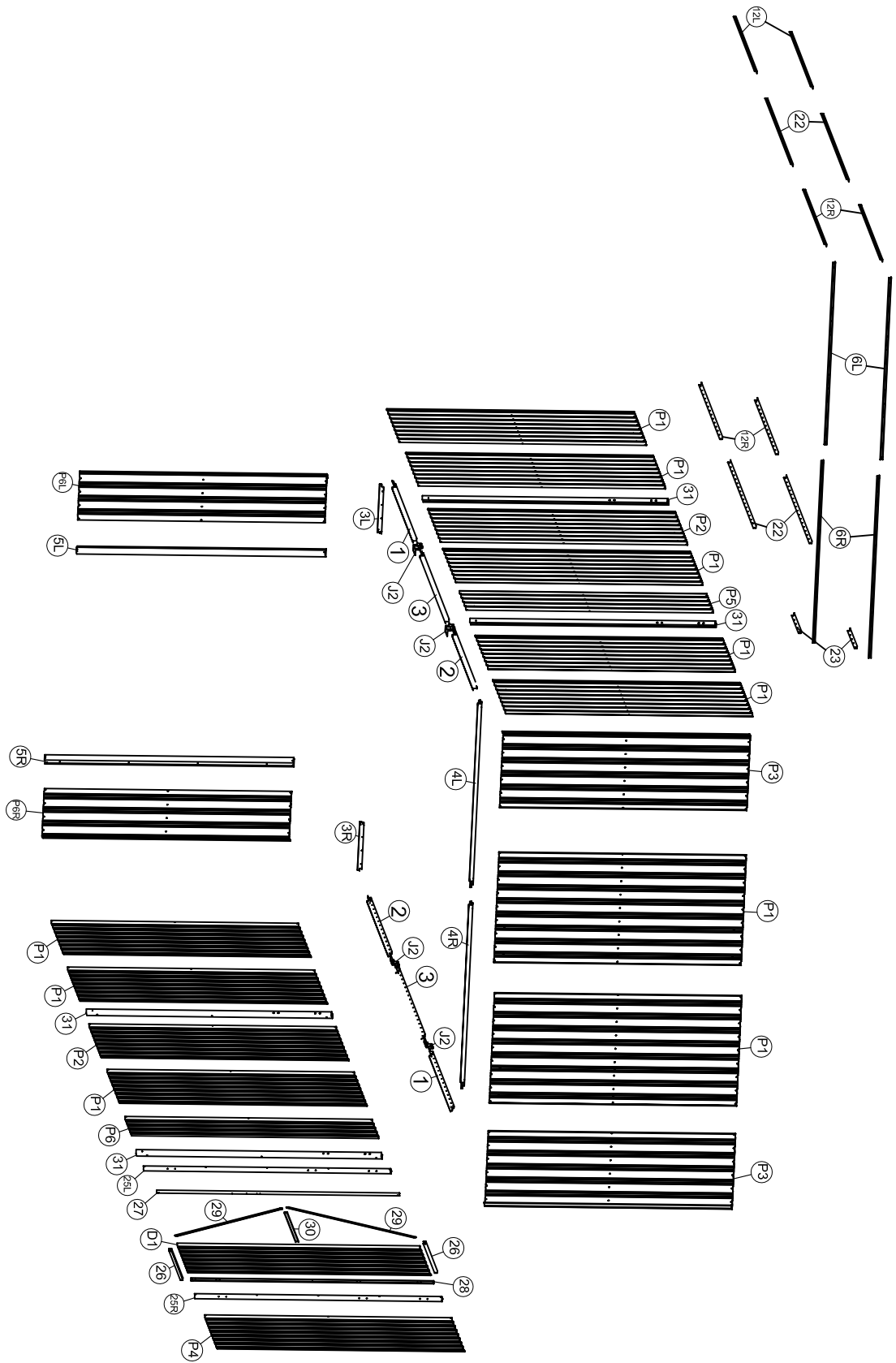

YLEINEN ULKOASUSNCG-C1

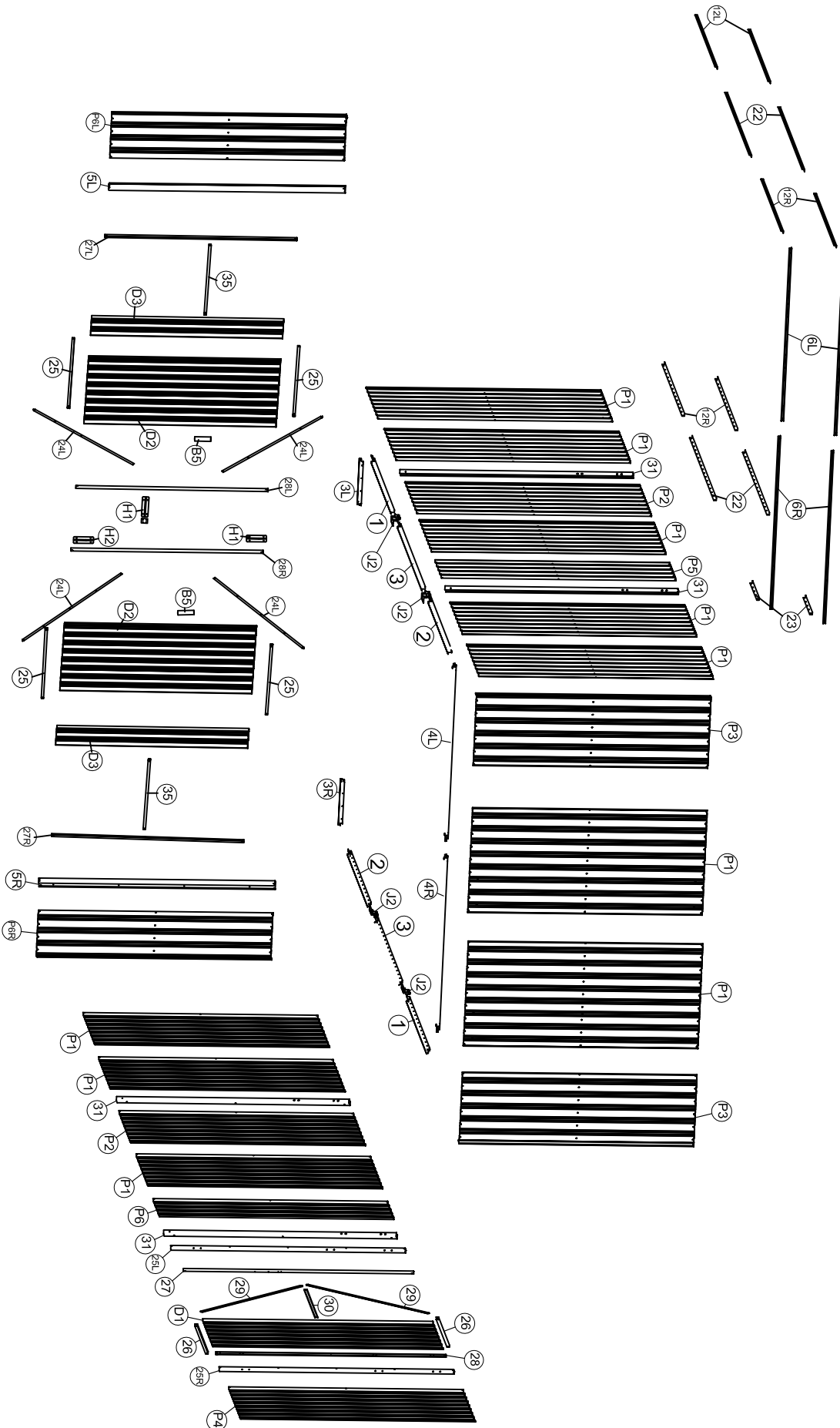

YLEINEN ULKOASUSNCG-A1 (SNCG-C1)

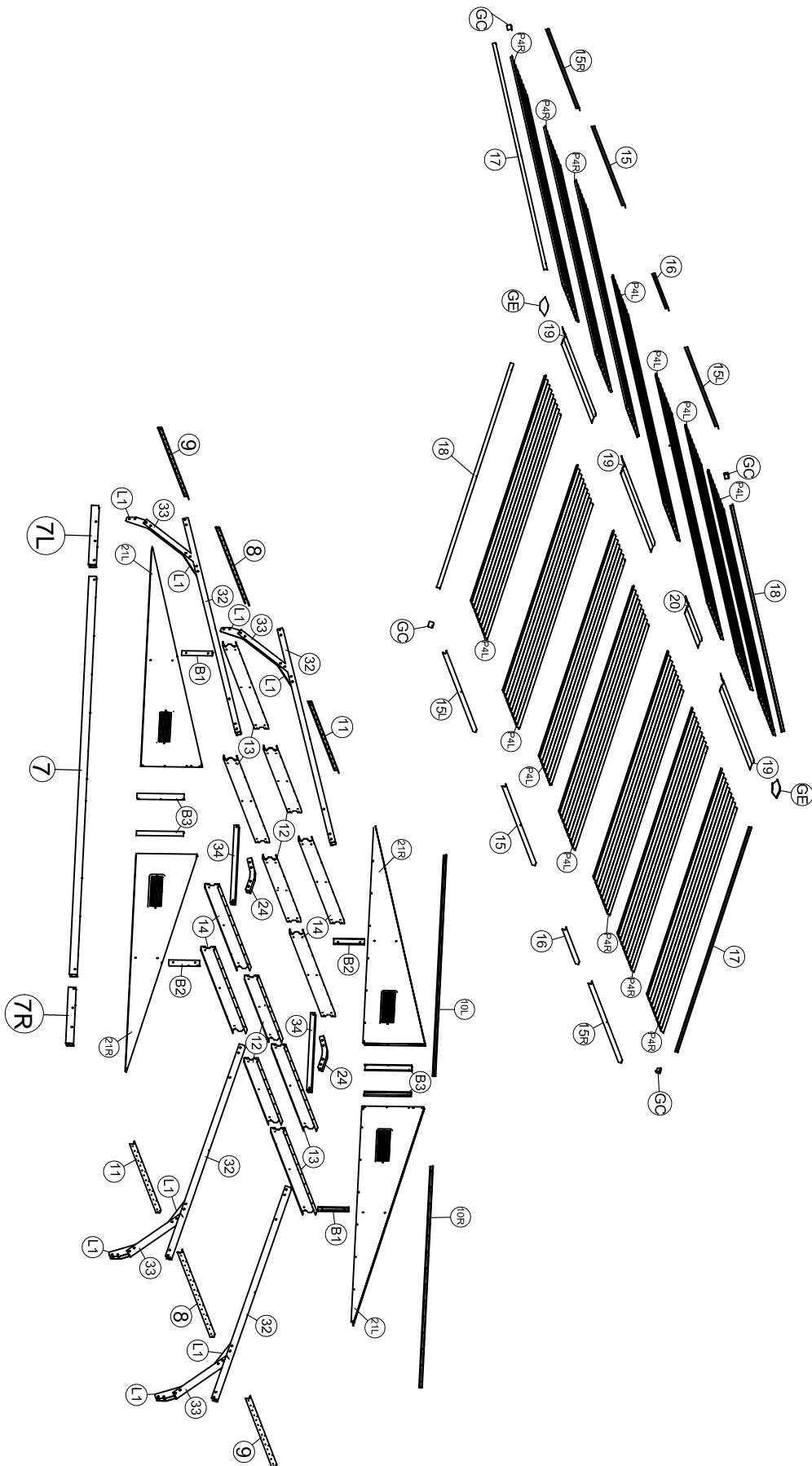

YLEINEN ULKOASUSNCG-C2

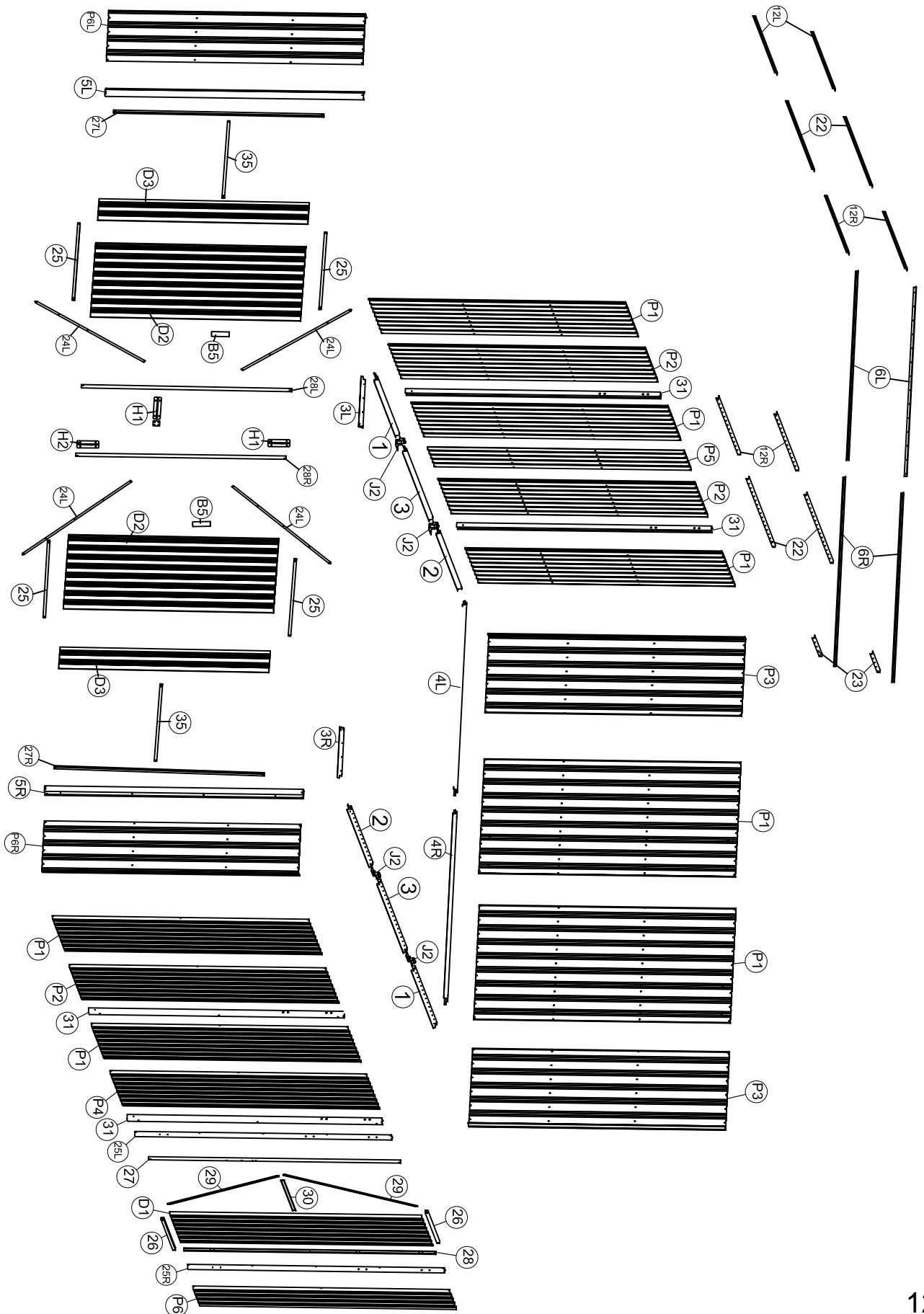

RUNGON KOKOAMINEN

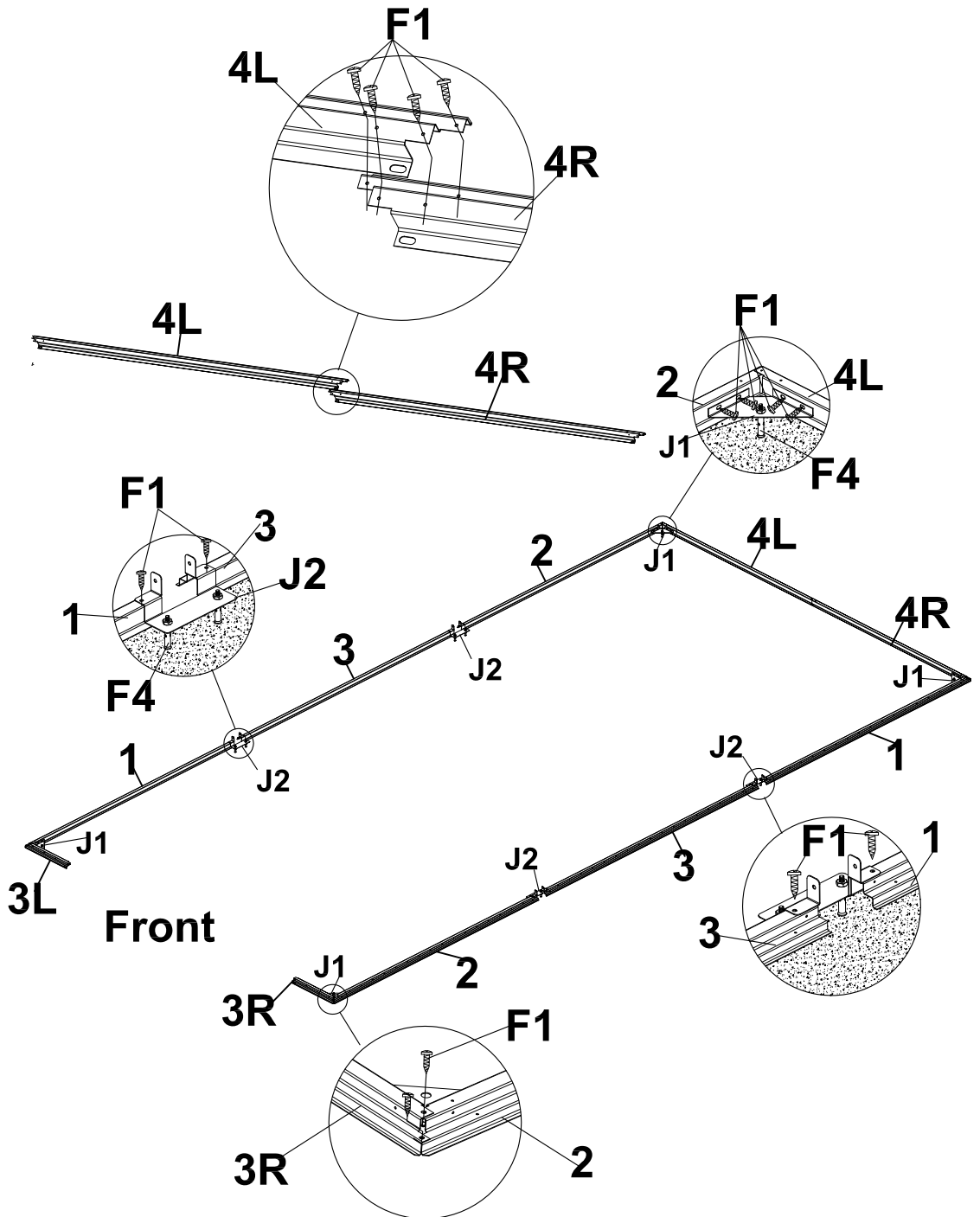

PART	NO.	Qty.
	1	2
	2	2
	3L	1
	3R	1
	4L	1
	4R	1
	3	2
	J1	4
	J2	4
	F1	
	F4	

Varo teräviä kulmia, käytä suojakäsineitä.

Etsi kuvissa olevat osat ja järjestele kuvien mukaisesti. Kiinnitä osat ruuveilla (F1). Varmista, että runko on täysin neliön muotoinen.

* Varmista, että runkopalkit ovat täysin neliön muotoiset.

* Rungossa on ylimääräisiä reikiä. Niitä voidaan käyttää rungon kiinnittämiseksi puu- tai betonialustaan.

* Parempaan turvallisuuteen varmistamiseksi suosittelemme, että käytät ankkurointisarjojamme.

SIVUSEINÄN KOKOAMINEN SNCG-C2

Huomaa: jätä 7-8 cm tilaa
tolppien kummallekin puolelle kuvan mukaisesti

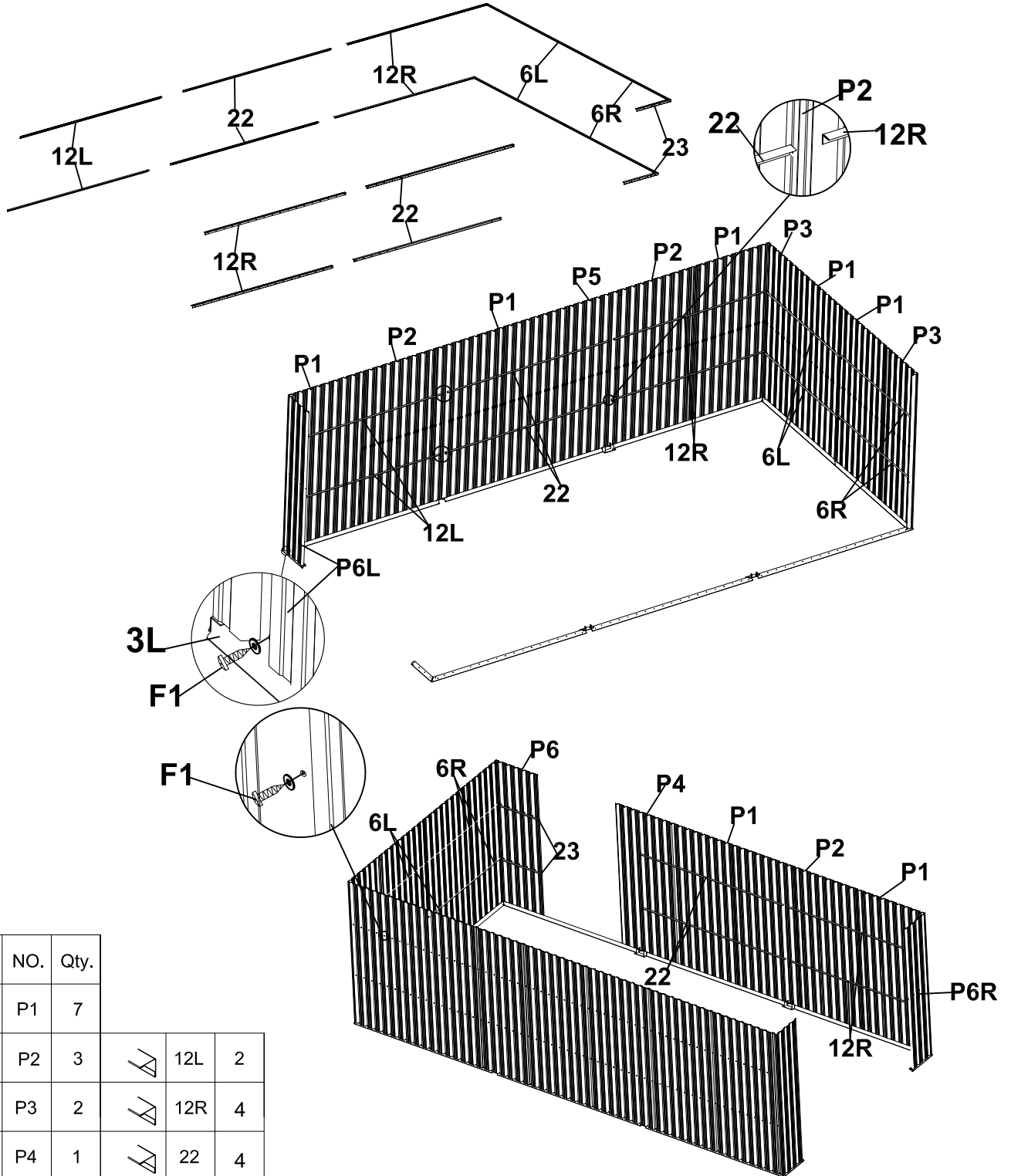

PART	NO.	Qty.			
	P1	7			
	P2	3		12L	2
	P3	2		12R	4
	P4	1		22	4
	P5	1		23	2
	P6	1		6L	2
	P6L	1		6R	2
	P6R	1		F1	

Varoitus! ÄLÄ TEE TÄTÄ KOHTAA TUULISENA PÄIVÄNÄ!

Etsi kuvan mukaiset osat. Aseta paneelit runkoon yksitellen ja kiinnitä tangot keskelle seinää samanaikaisesti, jotta seinä ei romahda.

SIVUSEINÄN KOKOAMINEN SNCG-A1 (SNCG-C1)

Huomaa: jätä 7-8 cm tilaa
tolppien kummallekin puolelle kuvan mukaisesti

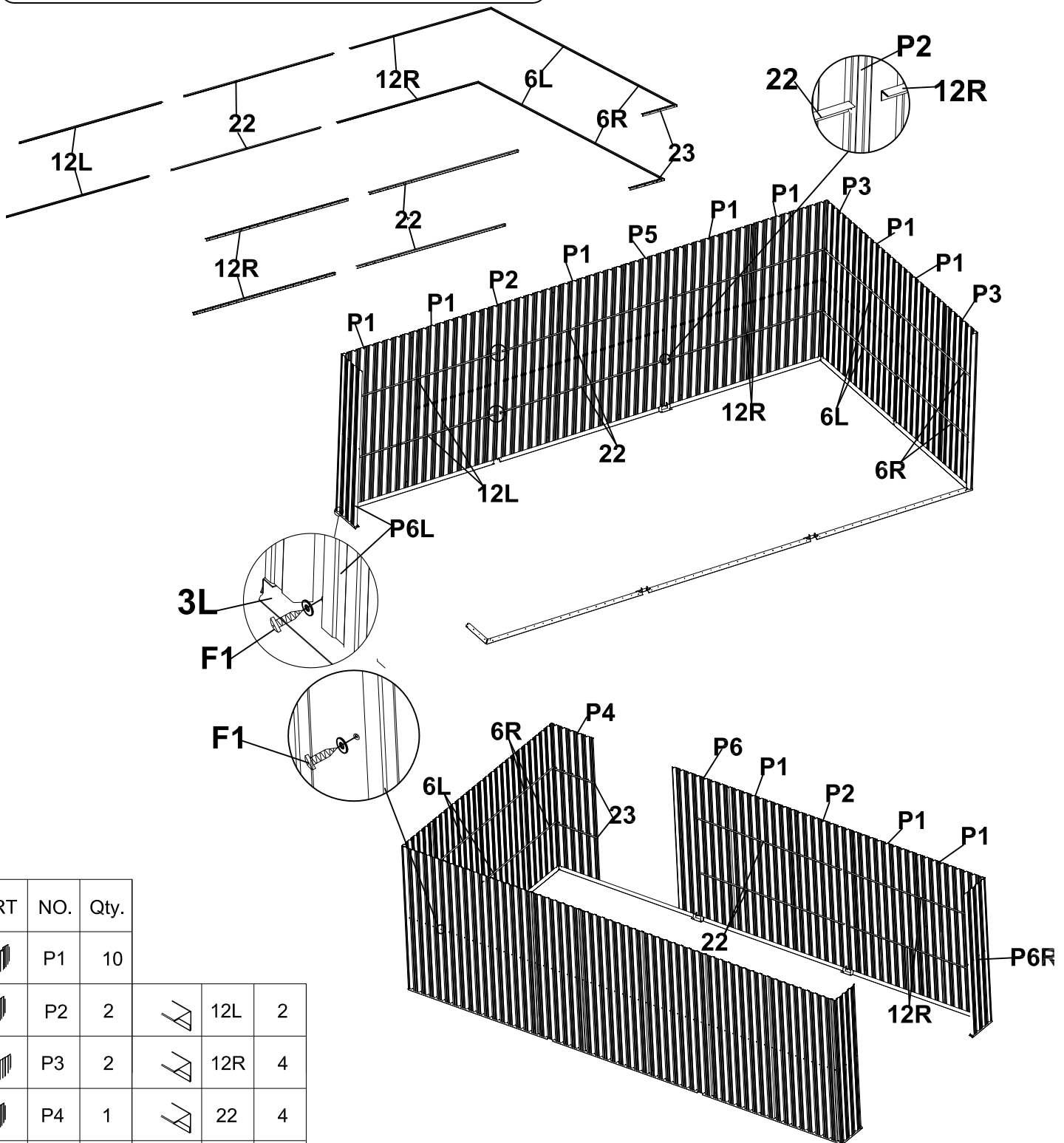





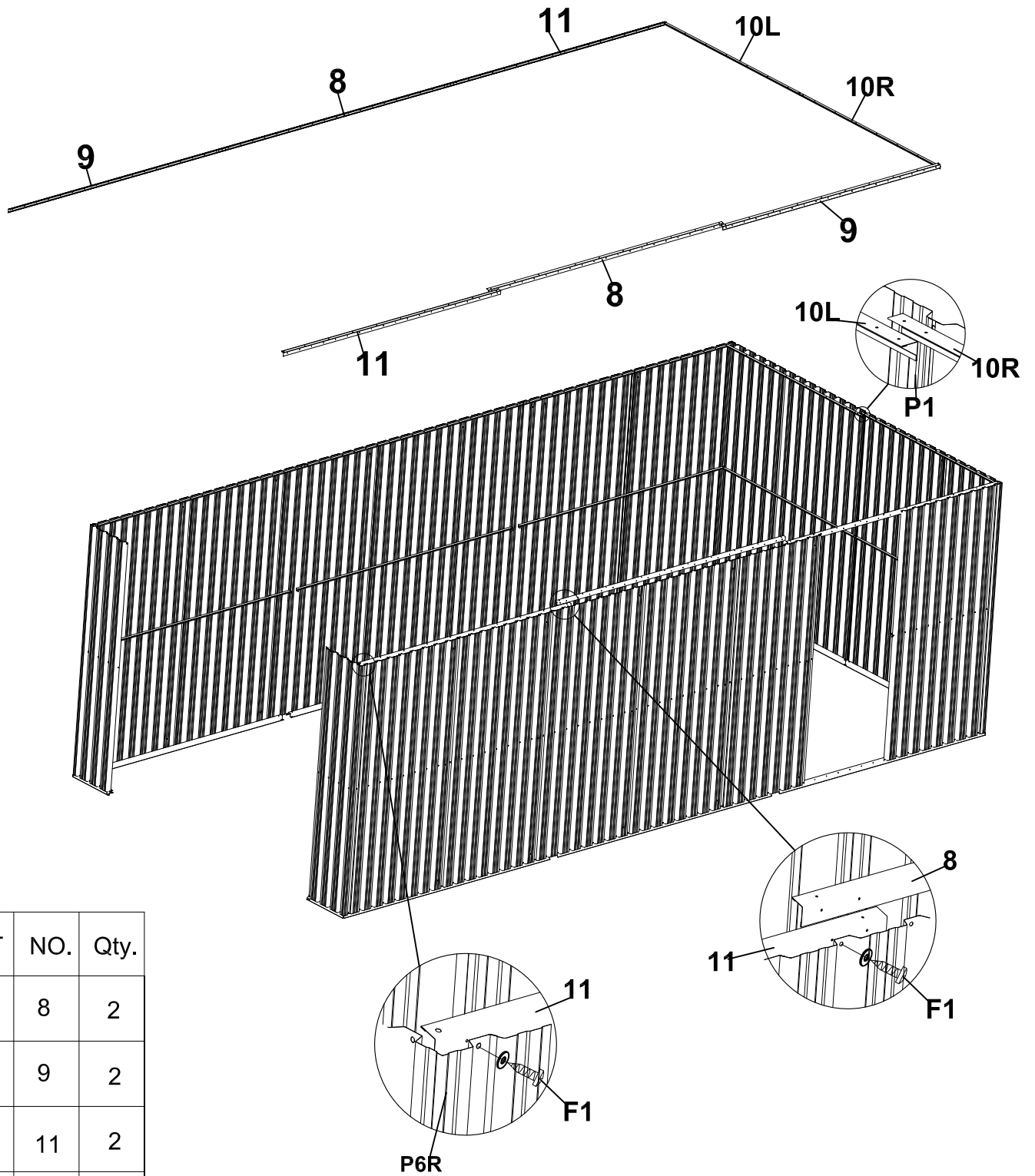

PART	NO.	Qty.		
	P1	10		
	P2	2		12L 2
	P3	2		12R 4
	P4	1		22 4
	P5	1		23 2
	P6	1		6L 2
	P6L	1		6R 2
	P6R	1		F1

Varoitus! ÄLÄ TEE TÄTÄ KOHTAA TUULISENA PÄIVÄNÄ!

Etsi kuvan mukaiset osat. Aseta paneelit runkoon yksitellen ja kiinnitä tangot keskelle seinää samanaikaisesti, jotta seinä ei romahda.

YLÄRUNGON ASENTAMINEN







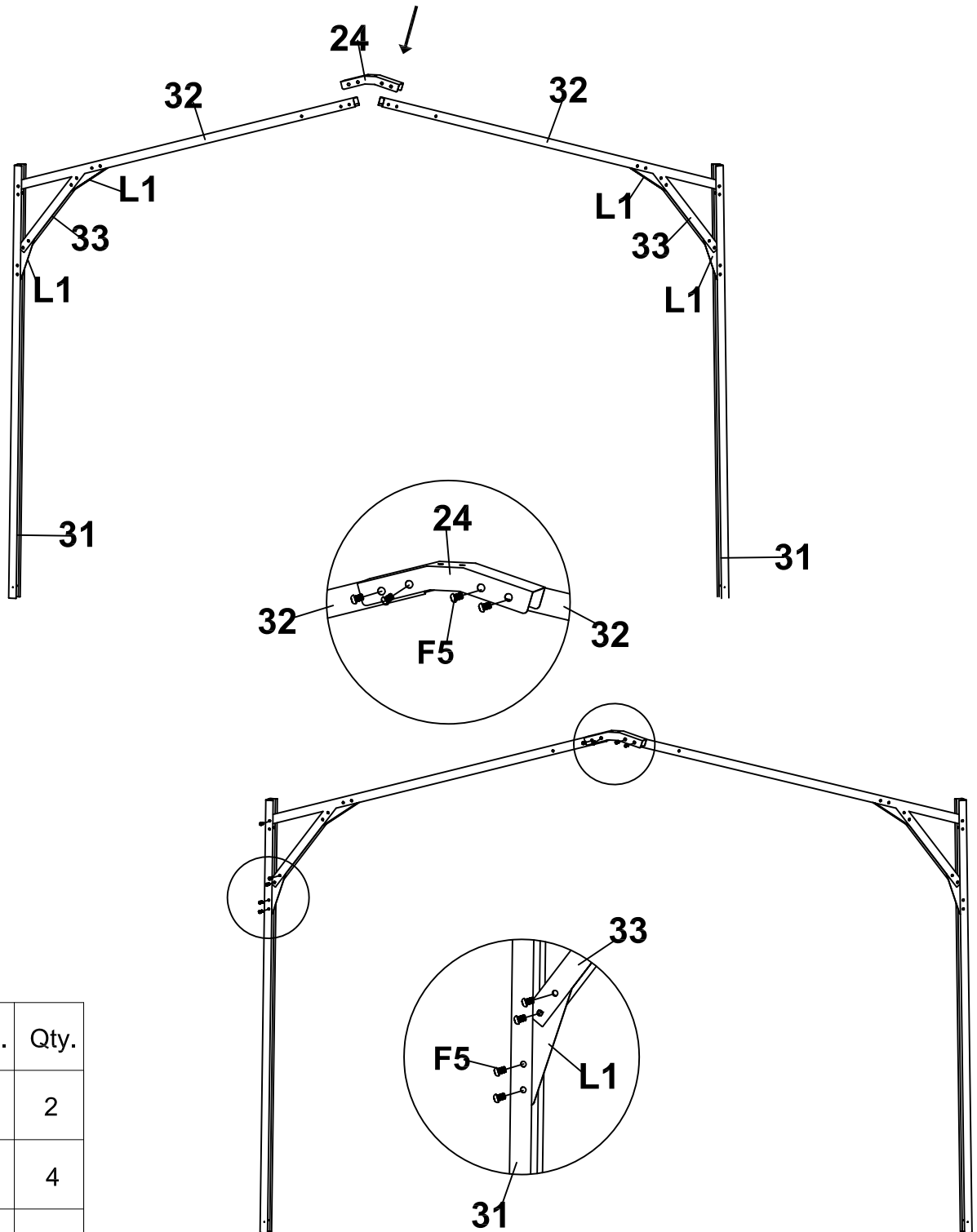

PART	NO.	Qty.
	8	2
	9	2
	11	2
	10L	1
	10R	1
	F1	

Kiinnitä ylätolpat kuvan mukaisesti ruuveilla ja aluslevyillä (F1).

TUKIRUNGON KOKOAMINEN, OSA 1



PART	NO.	Qty.
	24	2
	31	4
	32	4
	33	4
	L1	16
	F5	

Etsi luettelon mukaiset osat, kiinnitä toisiin yksitellen ruuveilla (F5).
Muista, että tukirunkoja on kaksi.

TUKIRUNGON KOKOAMINEN, OSA 2 SNCG-A1 (SNCG-C1)

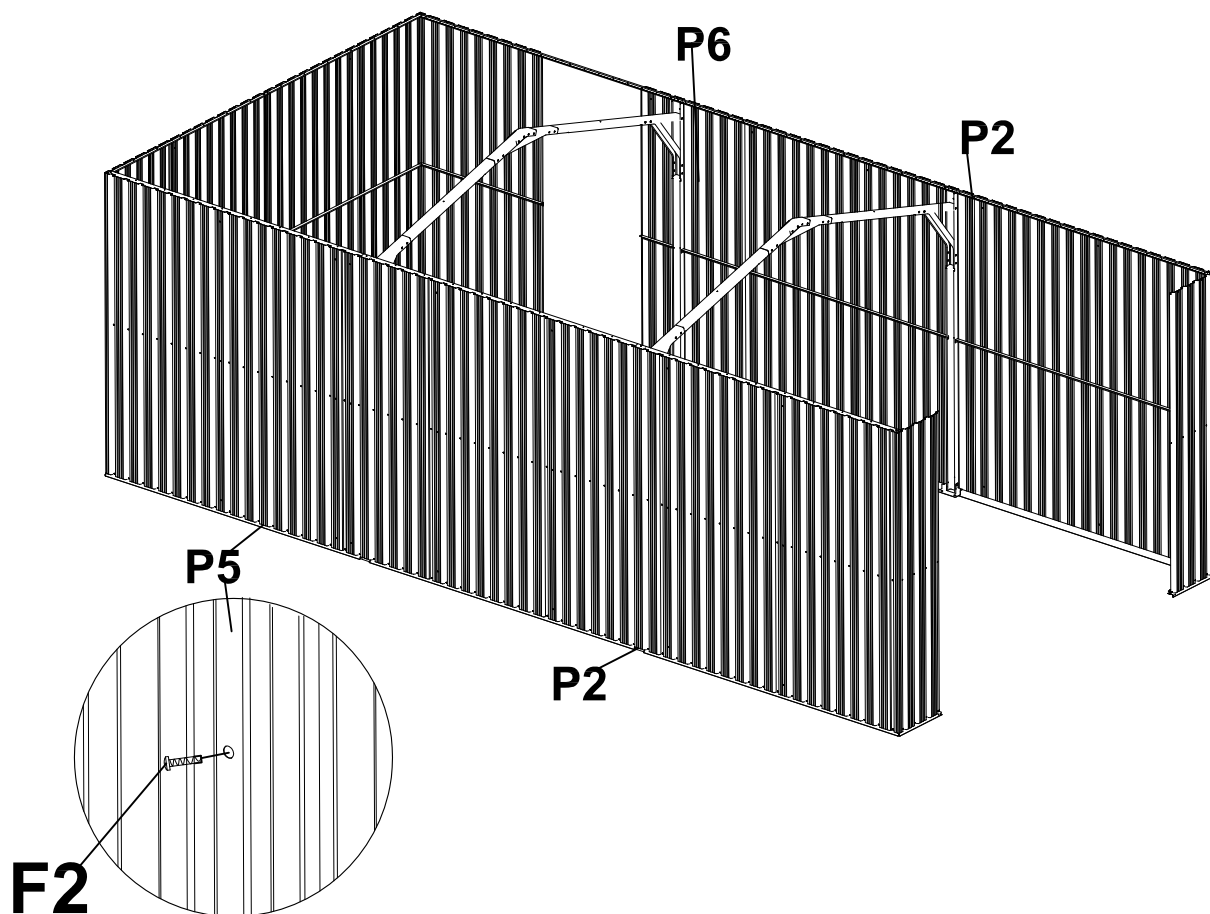

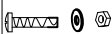
PART	NO.	Qty.
	F2	

Aseta tukirunko paikoilleen (huomaa seinäasennuksessa mainittu 7–8 cm:n tila), liitä paneeleihin ruuvein (F2).

TUKIRUNGON KOKOAMINEN, OSA 2 SNCG-C2

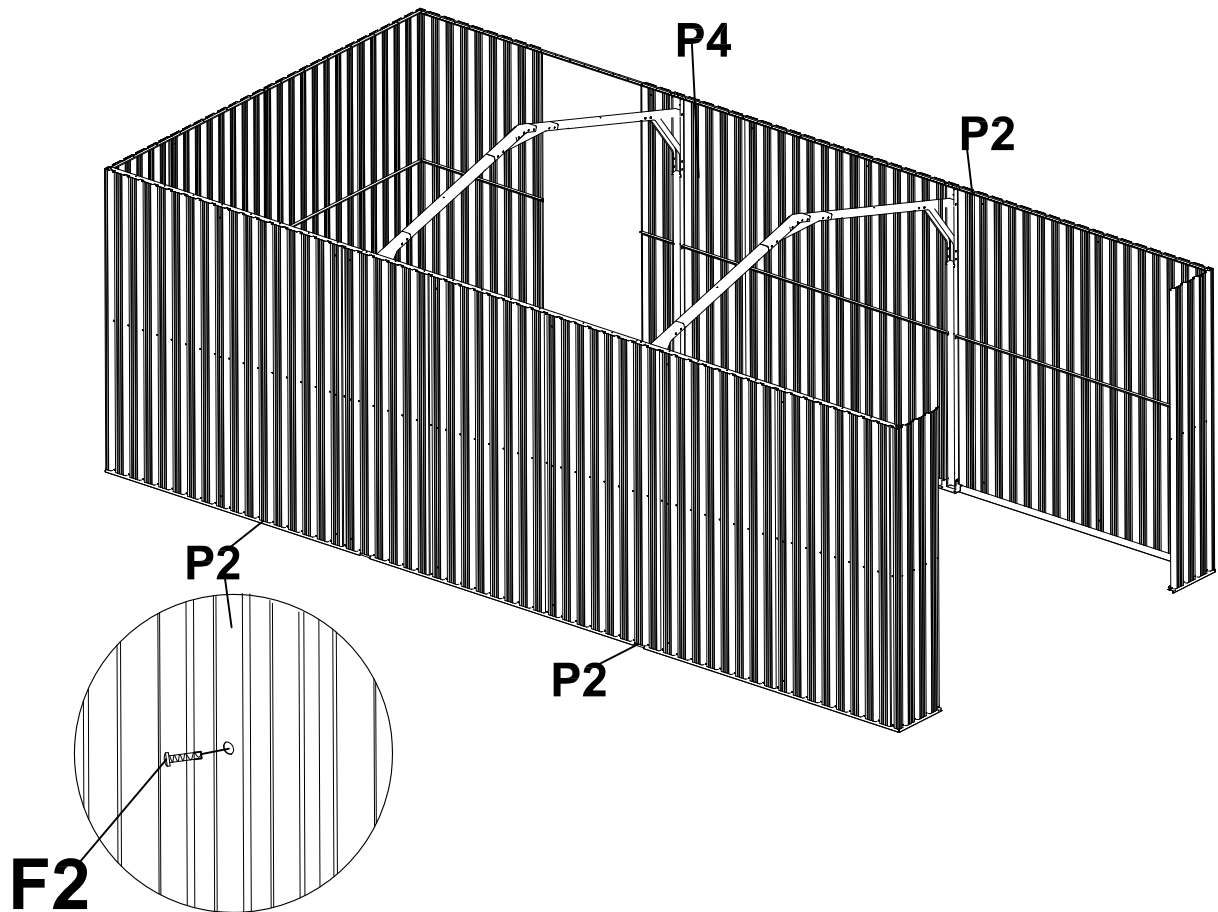

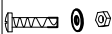



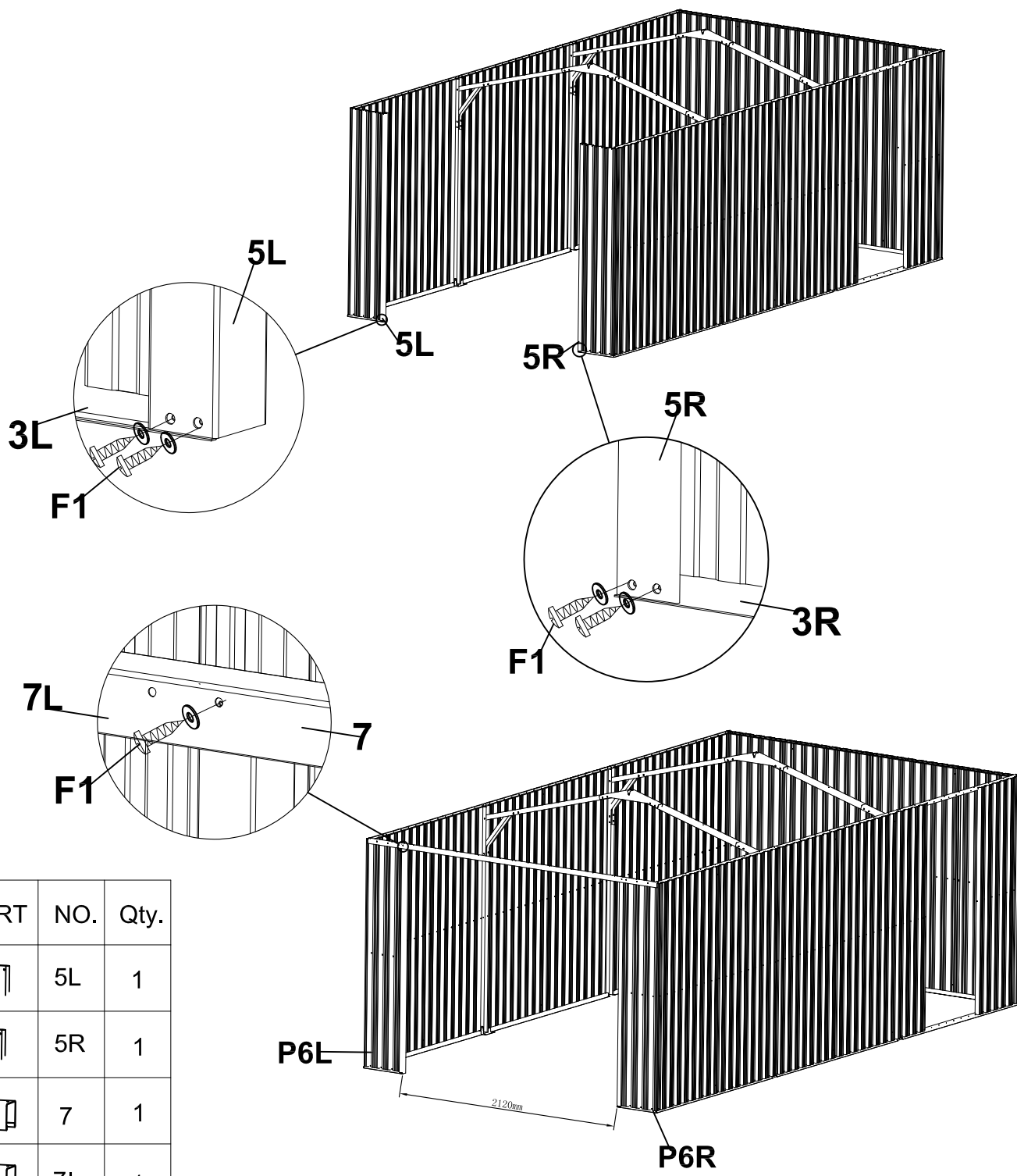

PART	NO.	Qty.
	F2	

Aseta tukirunko paikoilleen (huomaa seinäasennuksessa mainittu 7–8 cm:n tila), liitä paneeleihin ruuvein (F2).

OVIKARMIN KOKOAMINEN



PART	NO.	Qty.
	5L	1
	5R	1
	7	1
	7L	1
	7R	1
	F1	

Kiinnitä 5L ja 5R 3L:ään ja 3R:ään ruuvein (F1). Kiinnitä sitten nro 7 P6L:n ja P6R:n päälle ruuvein (F1).

PÄÄTYKOLMIION KOKOAMINEN

Huomaa: jokaiseen reikään tulee ruuvi

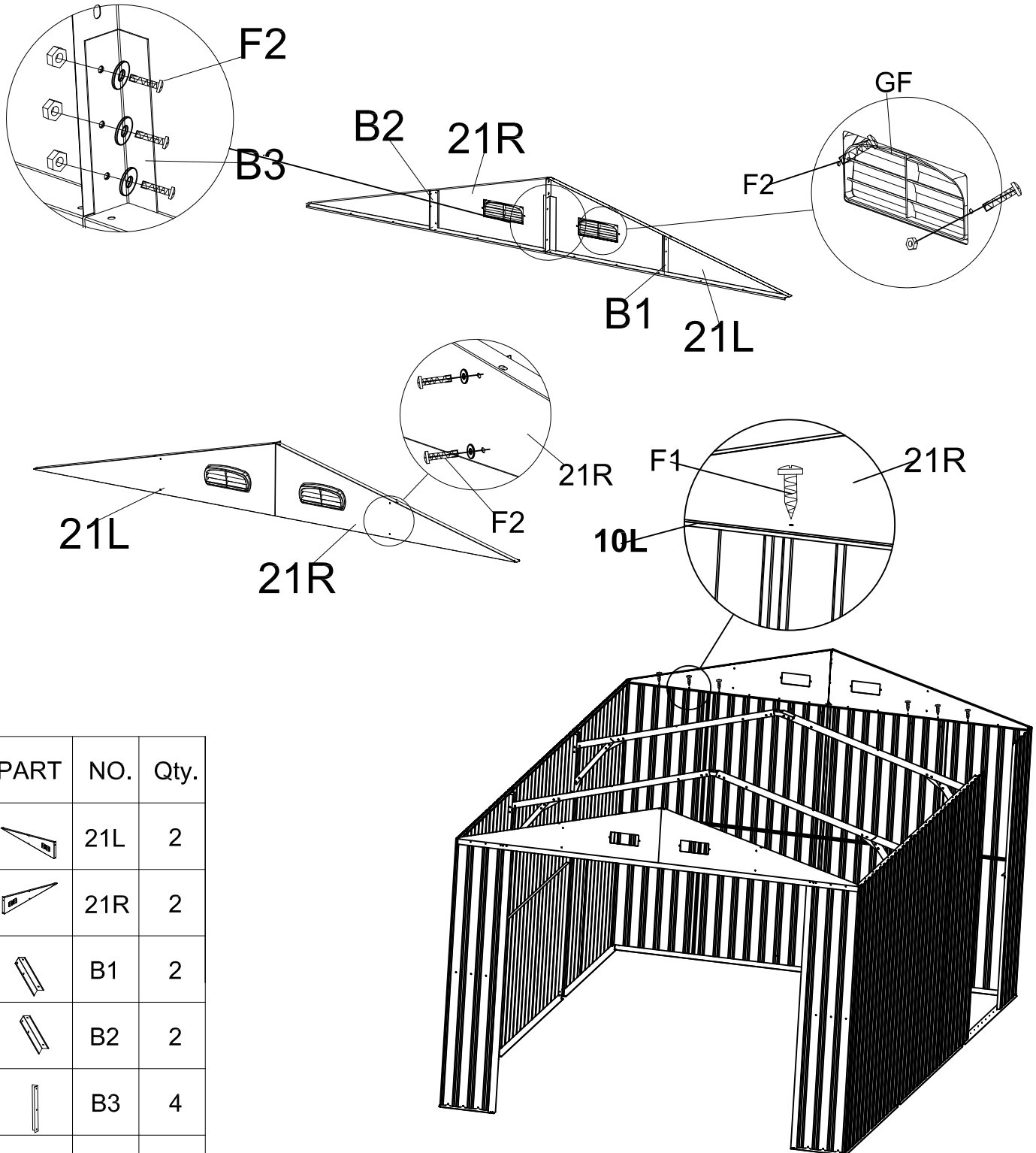



PART	NO.	Qty.
	21L	2
	21R	2
	B1	2
	B2	2
	B3	4
	GF	4
	F1	
	F2	

Etsi luettelossa olevat osat ja kokoa kaksi päätykolmiota (varmista, että asennat B1:n, B2:n ja B3:n oikein), ja kiinnitä kolmiot.

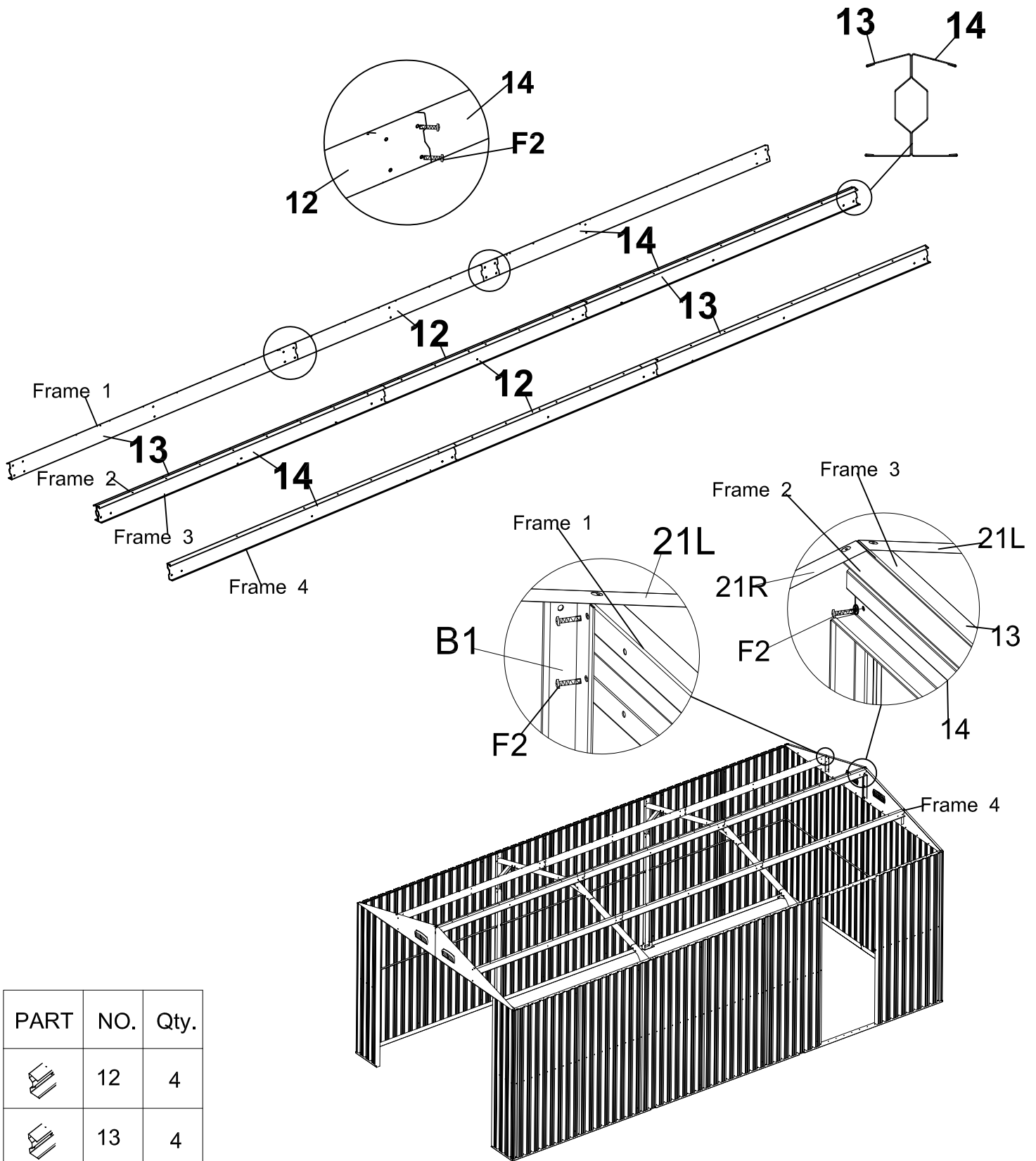
KATTOKEHIKON KOKOAMINEN

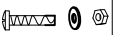

PART	NO.	Qty.
	12	4
	13	4
	14	4
	F2	

Liitä 4 kattokehikkoa kuvan mukaisella tavalla. Kiinnitä kehiot 2 ja 3 toisiinsa keskeltä.

KATTOPALKIN VAHVIKKEET, OSA 1

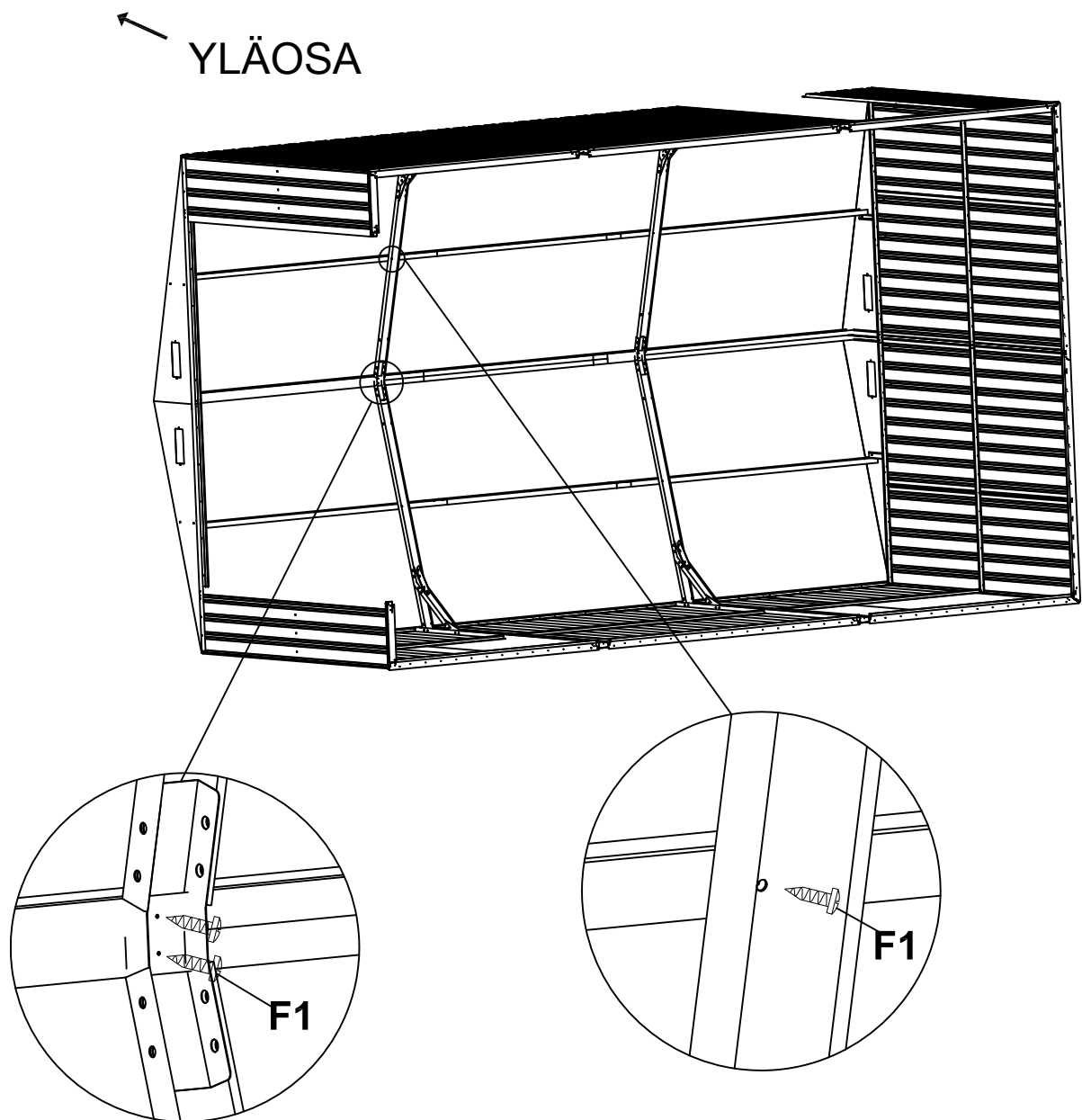



PART	NO.	Qty.
	F1	

Kiinnitä kattokehikot kattopalkkiin kahdella ruuvilla (F1).
Ruuvaa ruuvi (F1) tukikehikon toiselle puolelle.

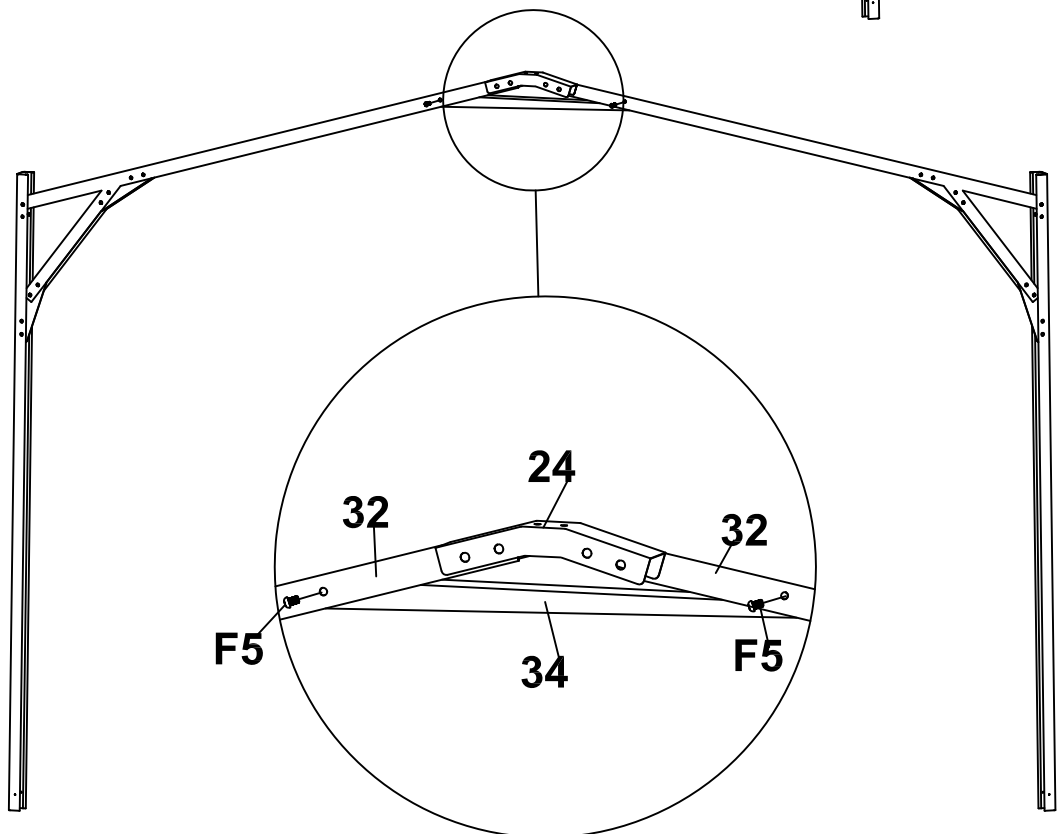
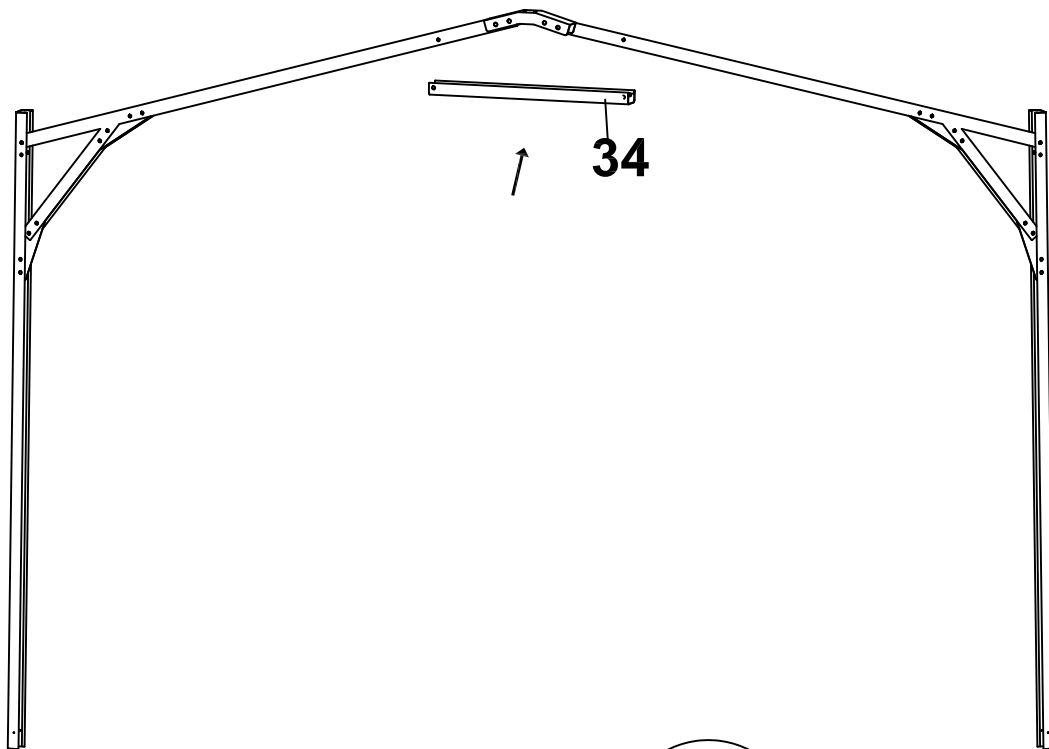
KATTOPALKIN VAHVIKKEET, OSA 2



PART	NO.	Qty.
	34	2
	F5	

Asenna osa nro 34 tukirungon yläosaan.

OVIENTYÖKOKOAMINEN, OSA 1

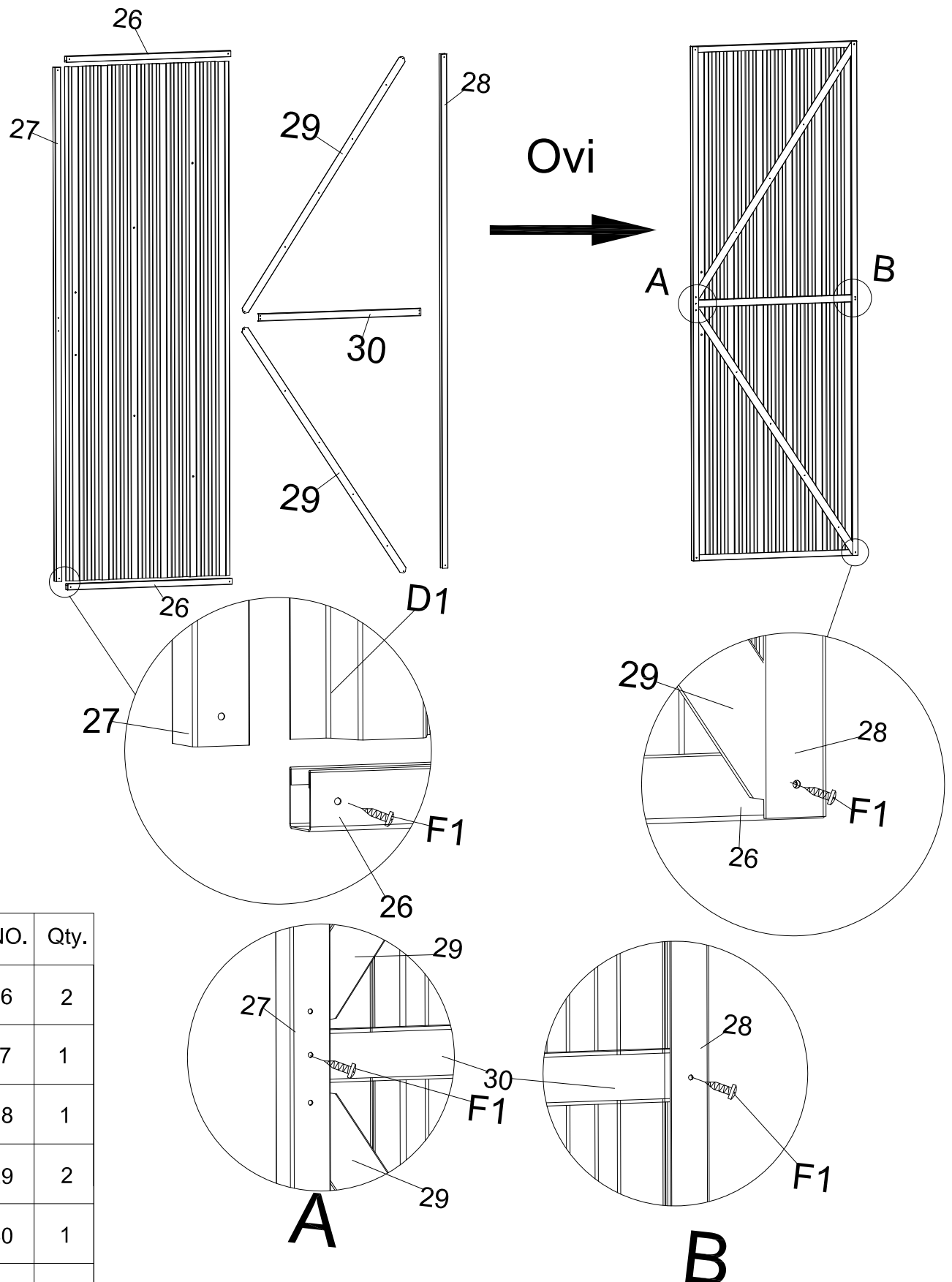



PART	NO.	Qty.
	26	2
	27	1
	28	1
	29	2
	30	1
	D1	1
	F1	

Kiinnitä osat 26, 27, 28, 29 ja 30 osaan D1 ruuveilla (F1) kuvan mukaisesti.
Varmista, että kiinnität osat oven takaosaan.

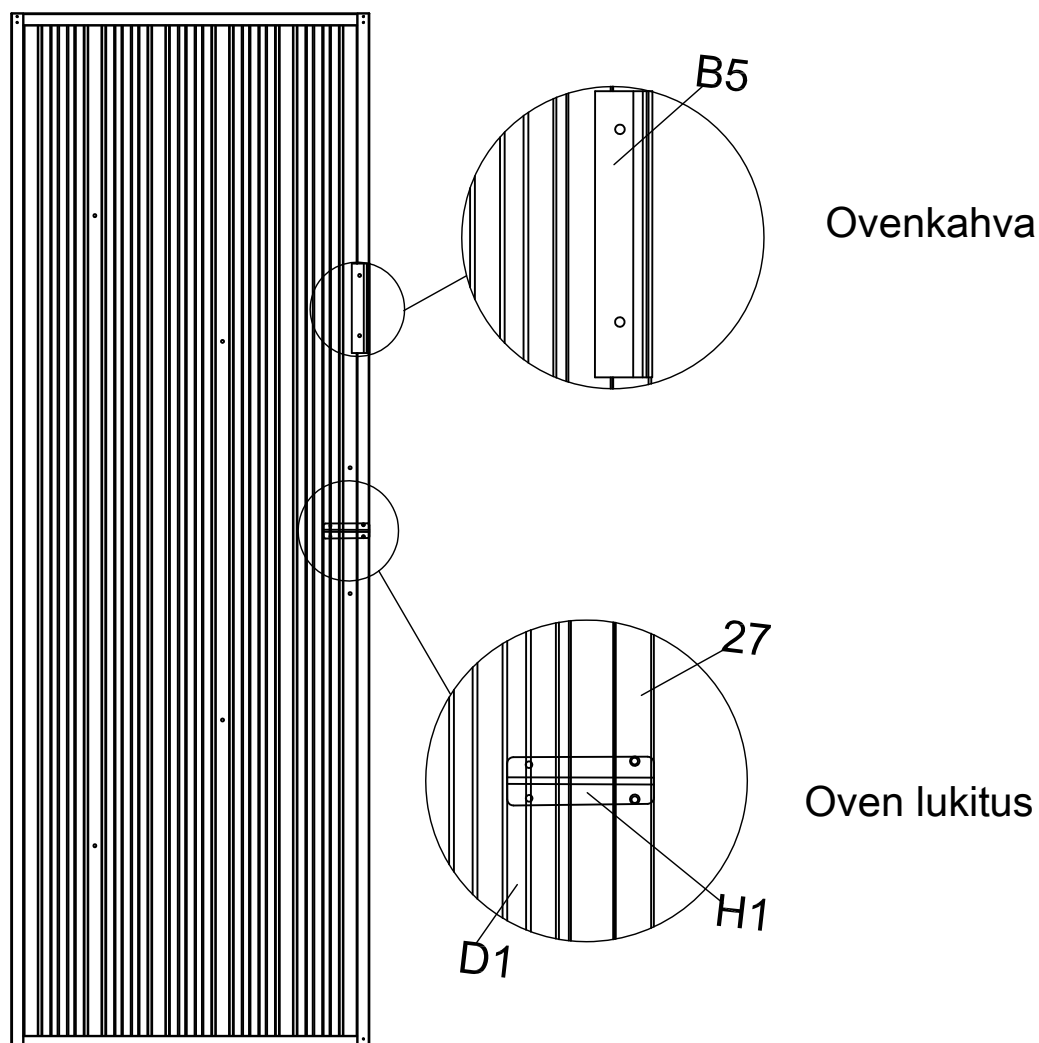
OVIEŒ KOKOAMINEN, OSA 2







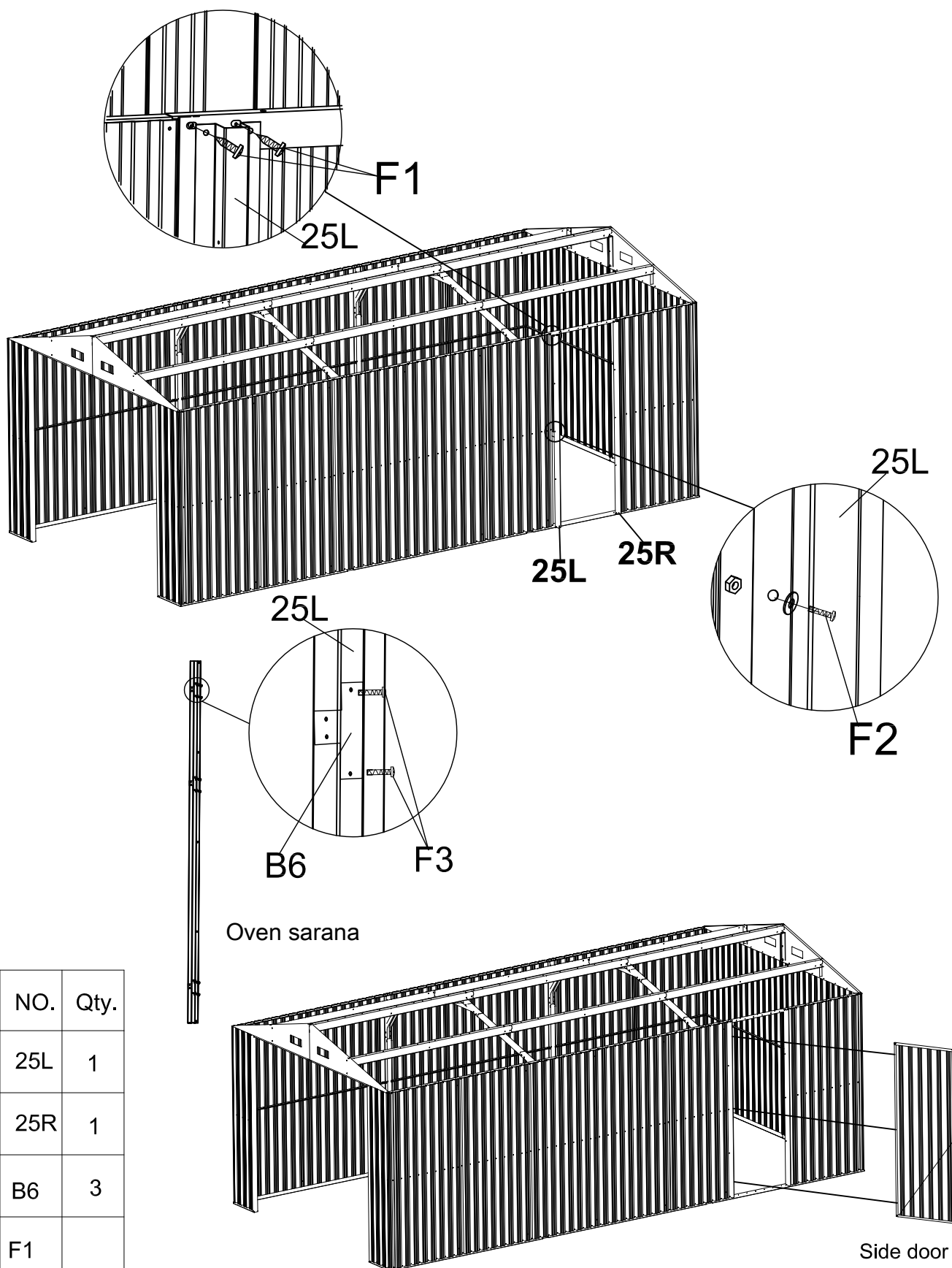

PART	NO.	Qty.
	B5	1
	H1	1
	F1	

Kiinnit osat B5 ja H1 ruuveilla (F1) oven etupuolelle.

OVIEŦ ASENŦUS

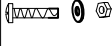





PART	NO.	Qty.
	25L	1
	25R	1
	B6	3
	F1	
	F2	
	F3	

Kokoa oven runko (nrot 25L ja 25R) ensin. Kiinnit sitten ovi (25L) osaan B6.

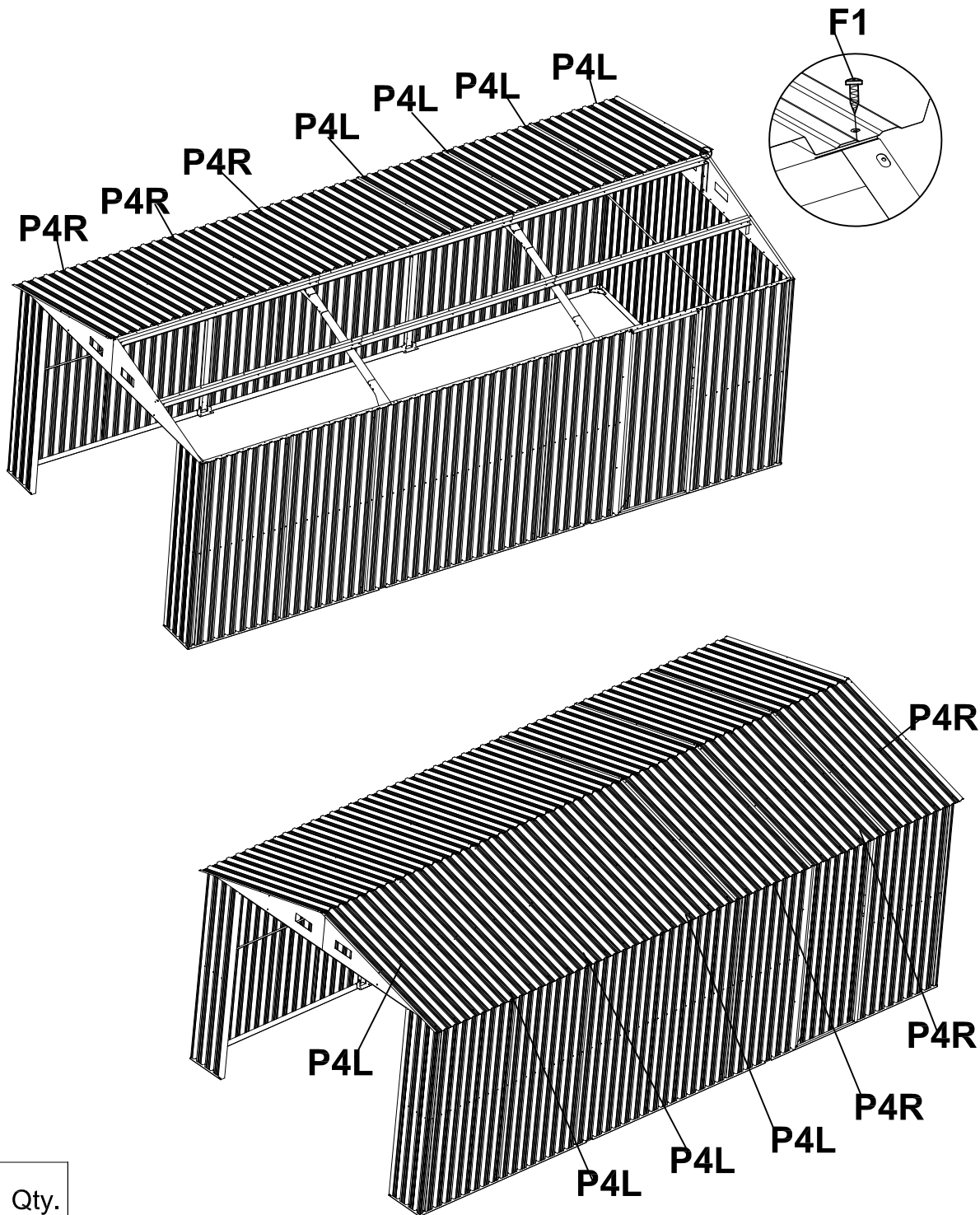
KATTOPANEELIEN KIINNITTÄMINEN SNCG-A1 (SNCG-C1)

Huomaa: kaikkiin paneelin reikiin tulee ruuvi.









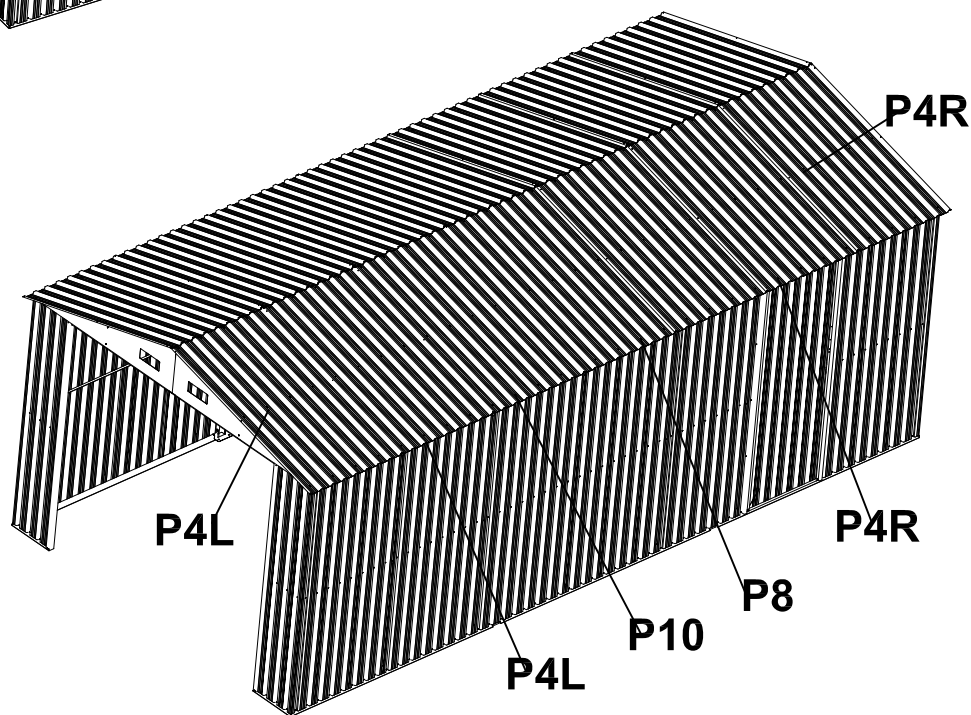
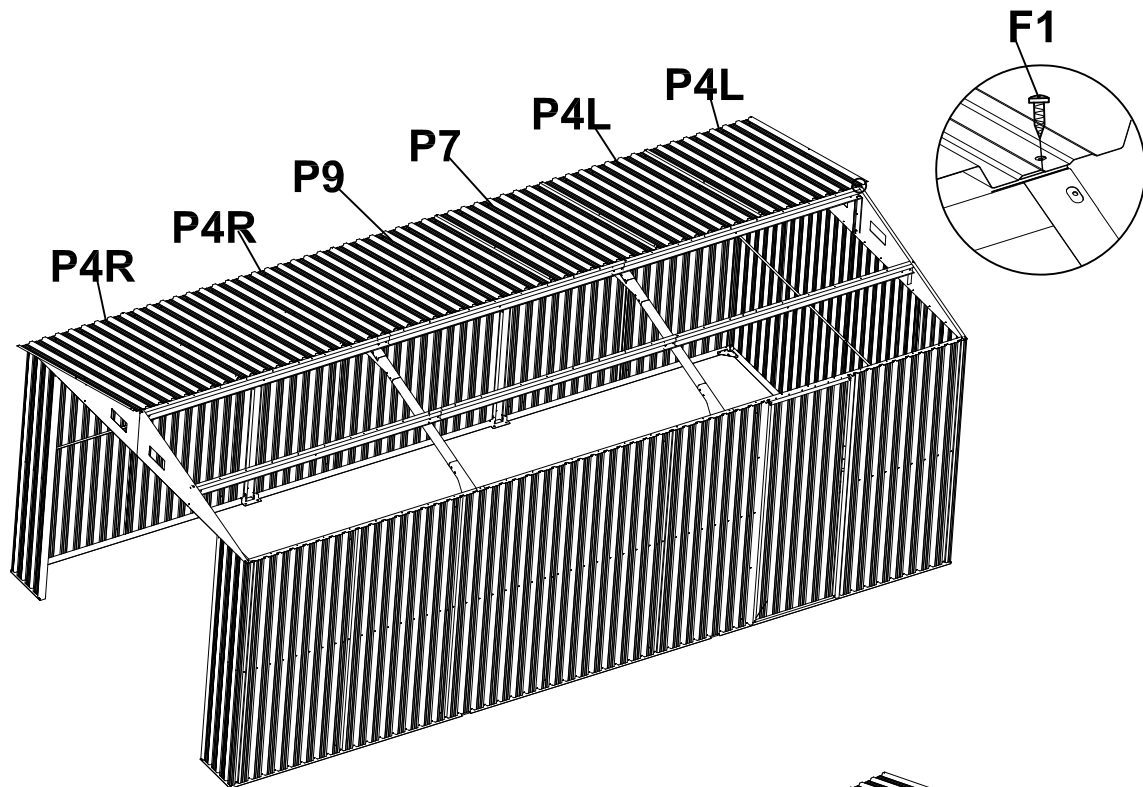

PART	NO.	Qty.
	P4L	8
	P4R	6
	F1	

Etsi luettelossa olevat osat. Asenna kattopaneelit yksitellen ruuveilla (F1).

KATTOPANEELIEN KIINNITTÄMINEN SNCG-C2

Huomaa: kaikkiin paneelin reikiin tulee ruuvi.









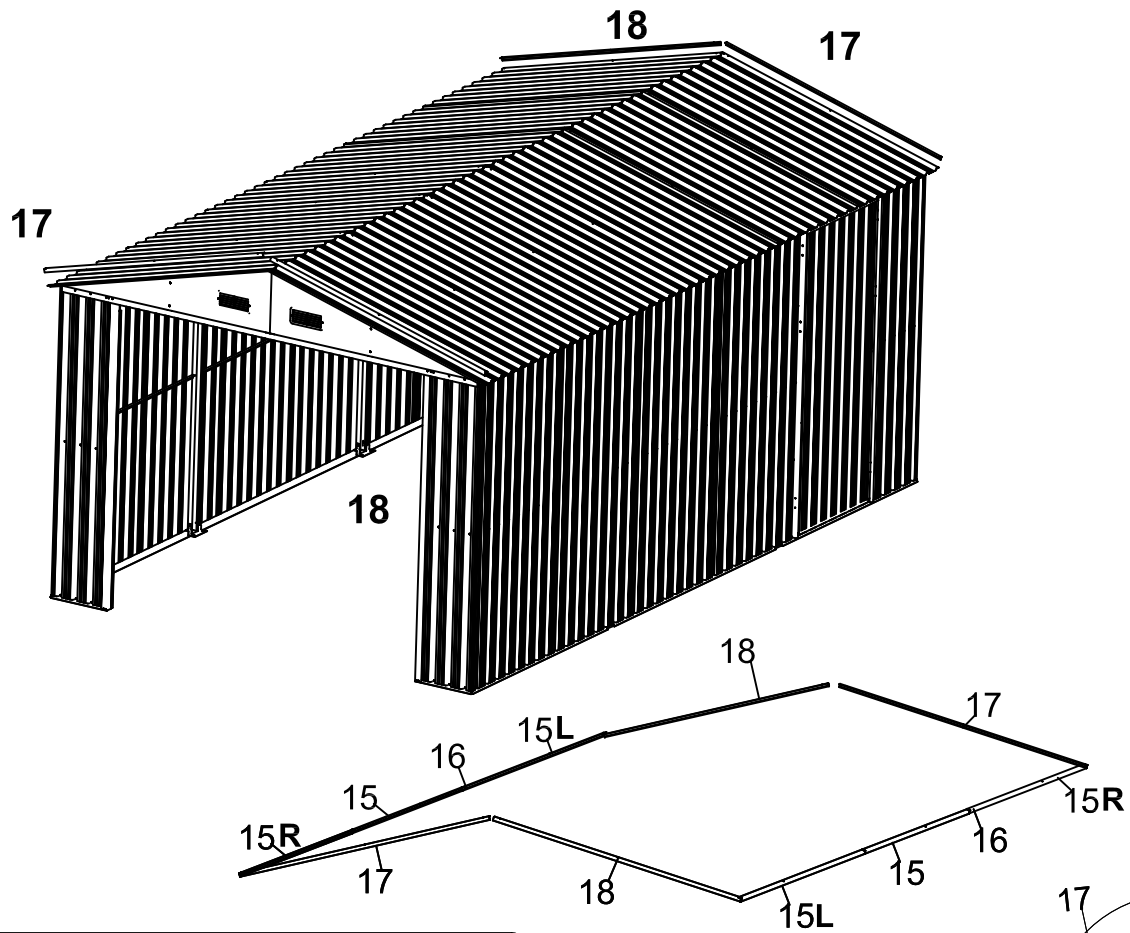

PART	NO.	Qty.
	P4L	4
	P4R	4
	P7	1
	P8	1
	P9	1
	P10	1
	F1	

Etsi luettelossa olevat osat. Asenna kattopaneelit yksitellen ruuveilla (F1).

LISTOJEN ASENNUS SNCG-A1 (SNCG-C1)



Huomaa: aseta ruuvi jokaiseen listan reikään

PART	NO.	Qty.
	15	2
	16	2
	15L	2
	15R	2
	17	2
	18	2
	GC	4
	GS	4
	F1	

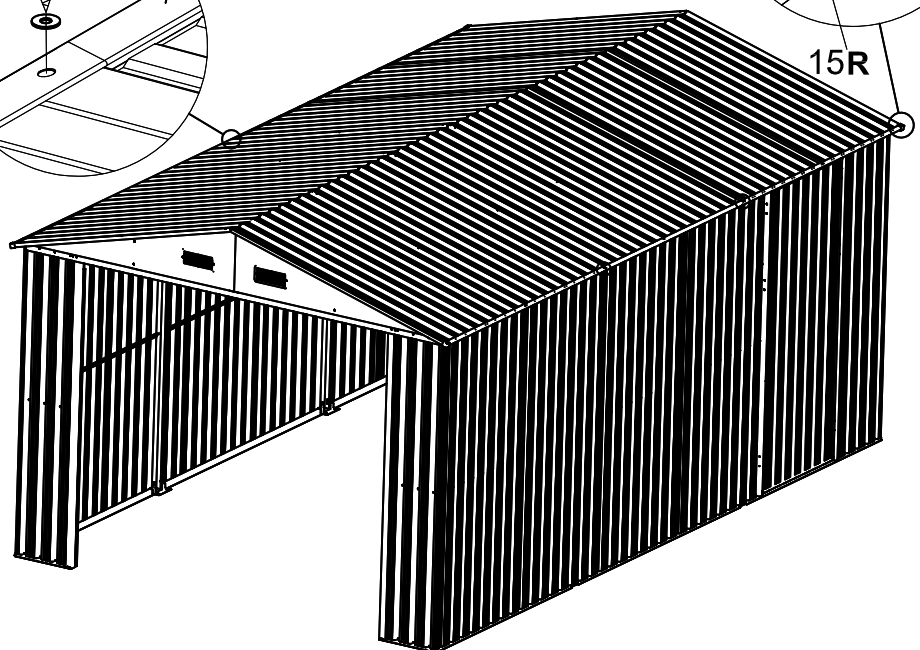
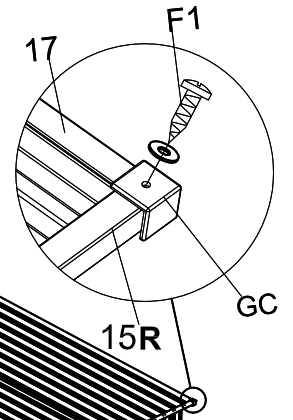
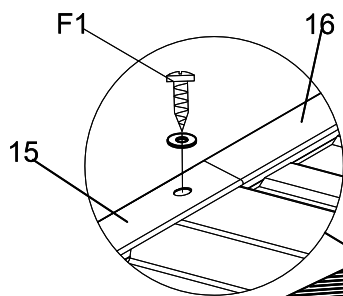

Kiinnitä katon reunoille kuvan mukaisesti. Aseta suojat (osa GC) jokaiseen kulmaan.

LISTOJEN ASENNUS SNCG-C2

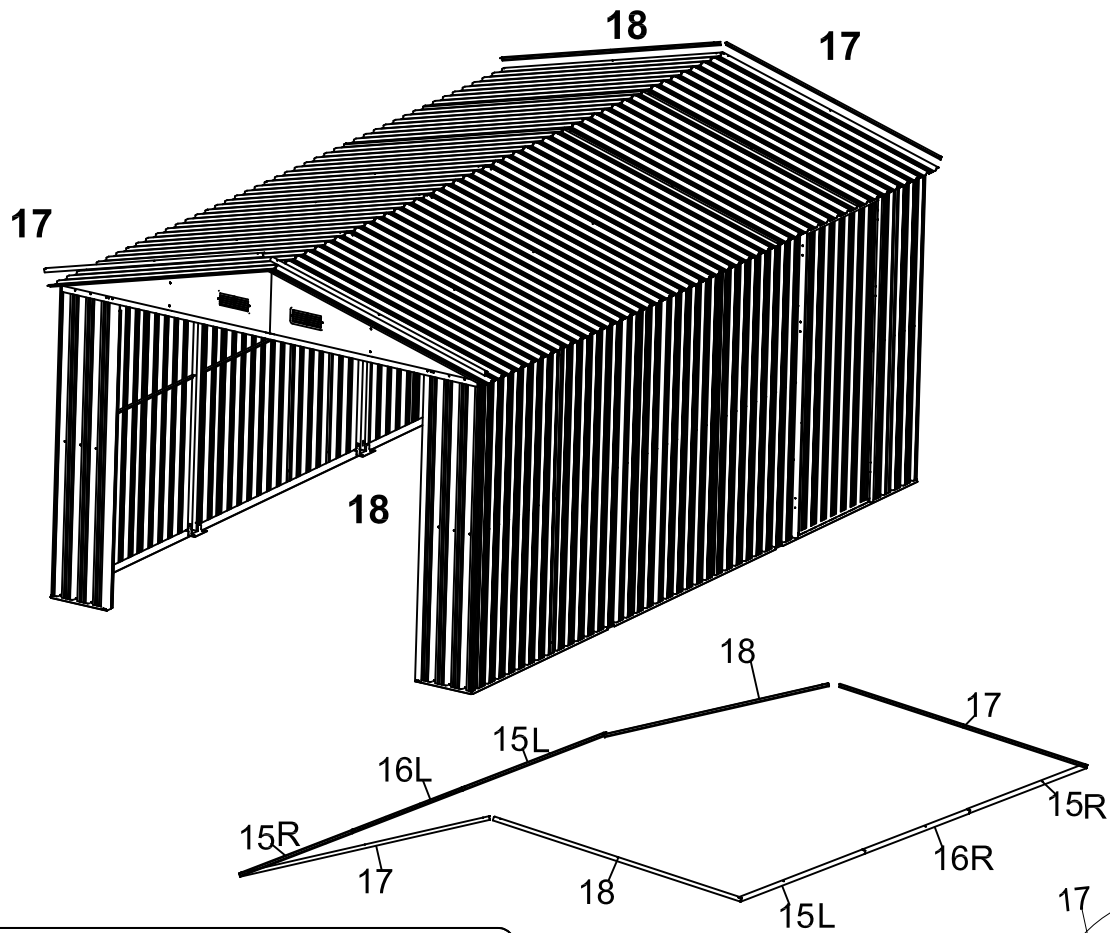

Huomaa: aseta ruuvi jokaiseen listan reikään

PART	NO.	Qty.
	15L	2
	15R	2
	16L	1
	16R	1
	17	2
	18	2
	GC	4
	GS	4
	F1	

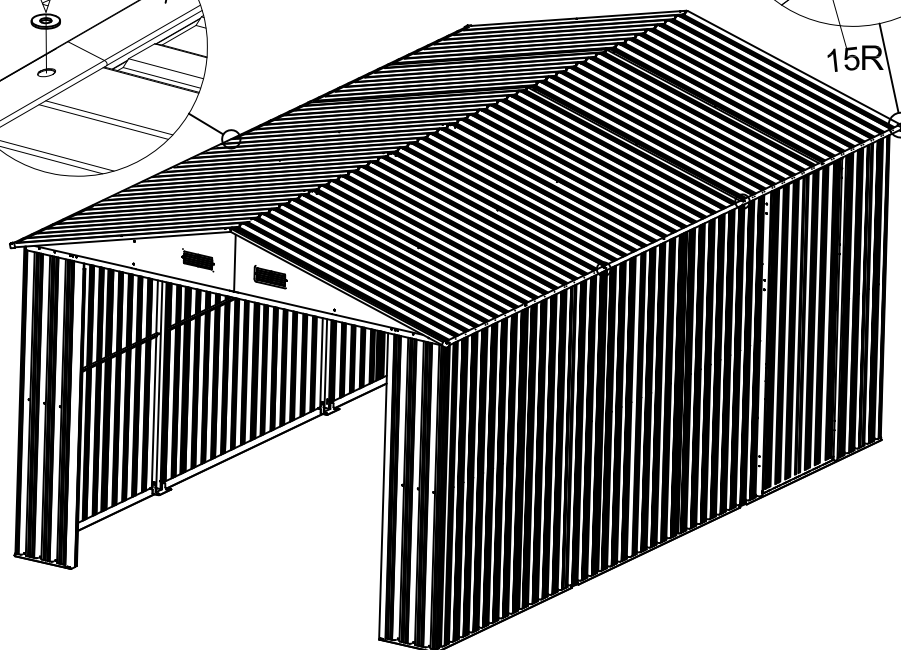
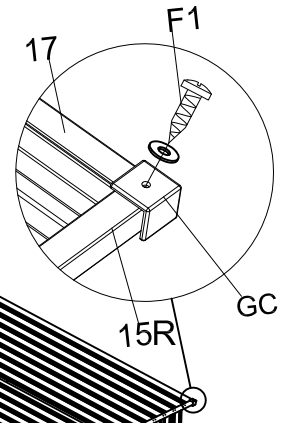
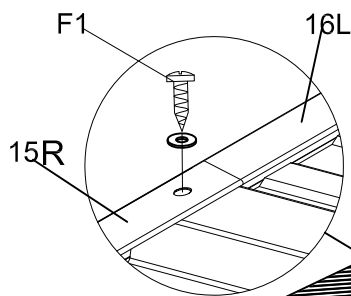

Kiinnitä katon reunoille kuvan mukaisesti. Aseta suojat (osa GC) jokaiseen kulmaan.

KATTOHARJAN SUOJAN ASENNUS

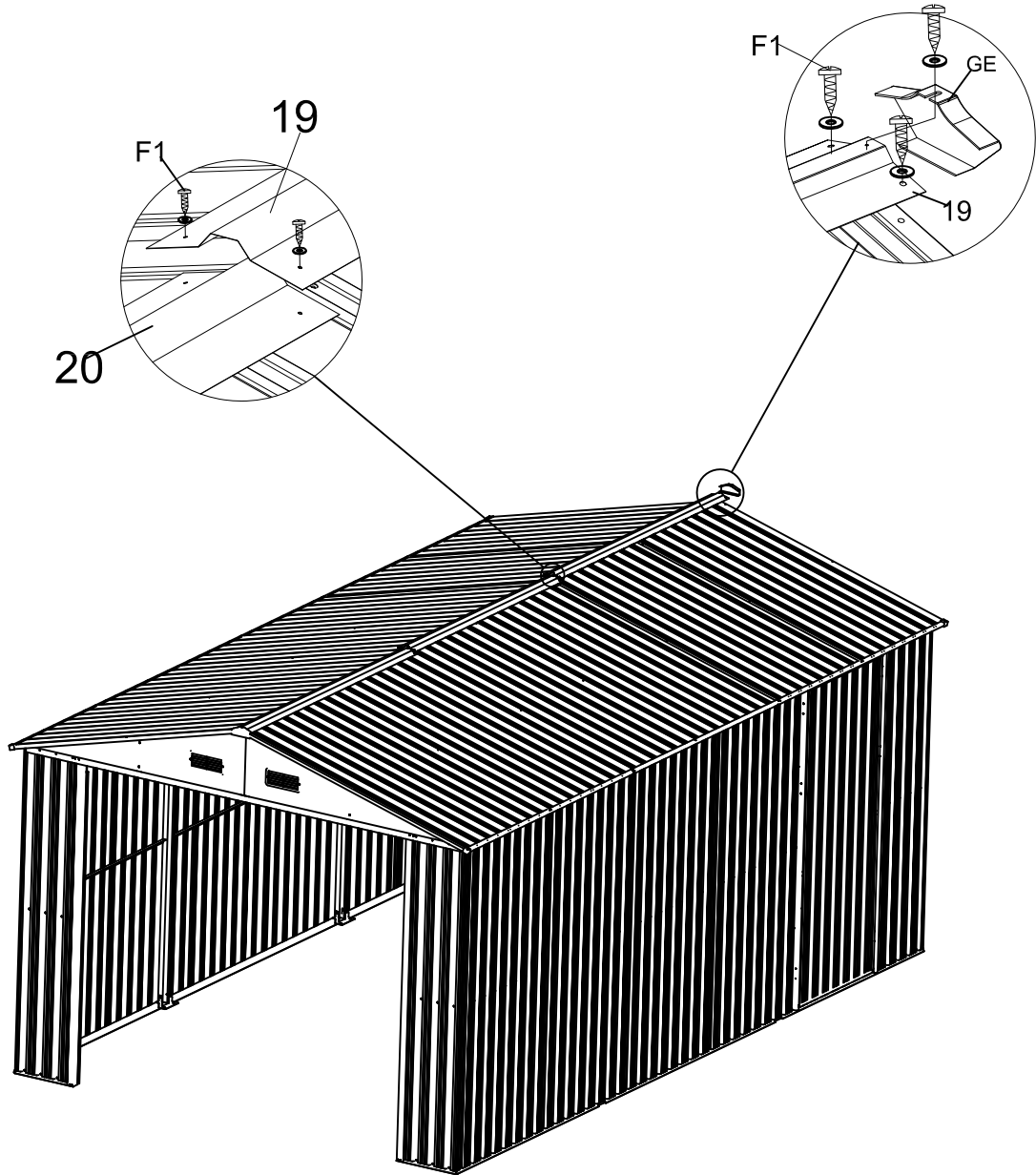





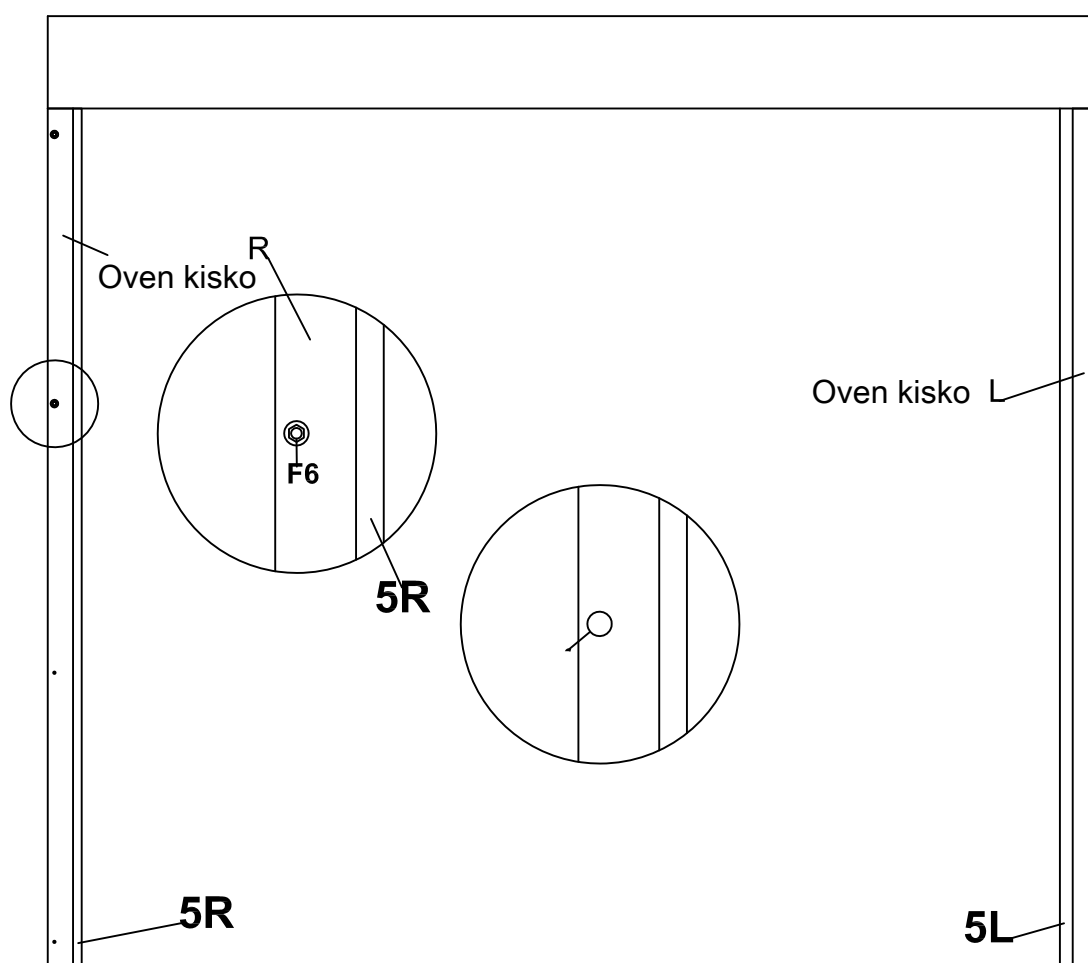

PART	NO.	Qty.
	19	2
	20	1
	GE	2
	F1	

Kiinnitä osat 19 ja 20 kattoharjaan. Kiinnitä osat GE kumpaankin pätyyn kuvan mukaisesti.

NOSTO-OVEN ASENNUS (MALLI SNCG-A1)

Nosto-oven moottori









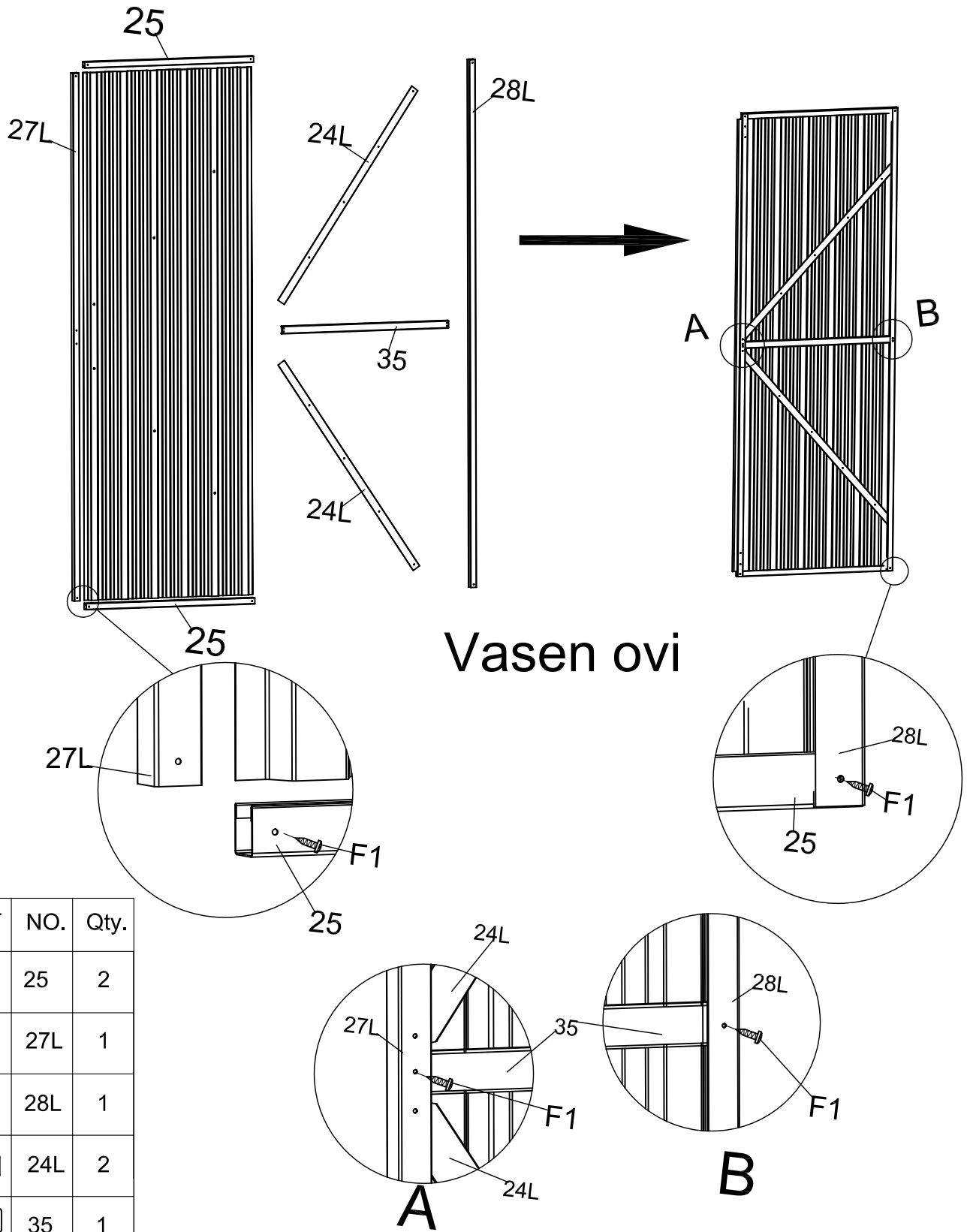

PART	NO.	Qty.	Remark
	Rolling door motor	1	white color
	Door rails L	1	white frame 1845mm
	Door rails R	1	white frame 1845mm
	Cover	8	white circle
	F6		
Automatic Motor Control			

Etsi luettelon mukaiset osat. Kiinnitä nosto-ovi sen kiskoihin, nosta se ja kiinnitä ovikehikkoon (5L ja 5R) ruuveilla F6.

OVIEEN KOKOAMINEN, OSA 1 (MALLIT SNCG-C1, C2)



Vasen ovi

PART	NO.	Qty.
	25	2
	27L	1
	28L	1
	24L	2
	35	1
	D2	1
	D3	1
	F1	

Kiinnitä osat 25, 27L, 28L, 24L ja 35 osiin D2 ja D3 ruuveilla (F1) kuvan mukaisesti. Varmista, että kiinnität osat oven takaosaan.

OVIEEN KOKOAMINEN, OSA 2 (MALLIT SNCG-C1, C2)

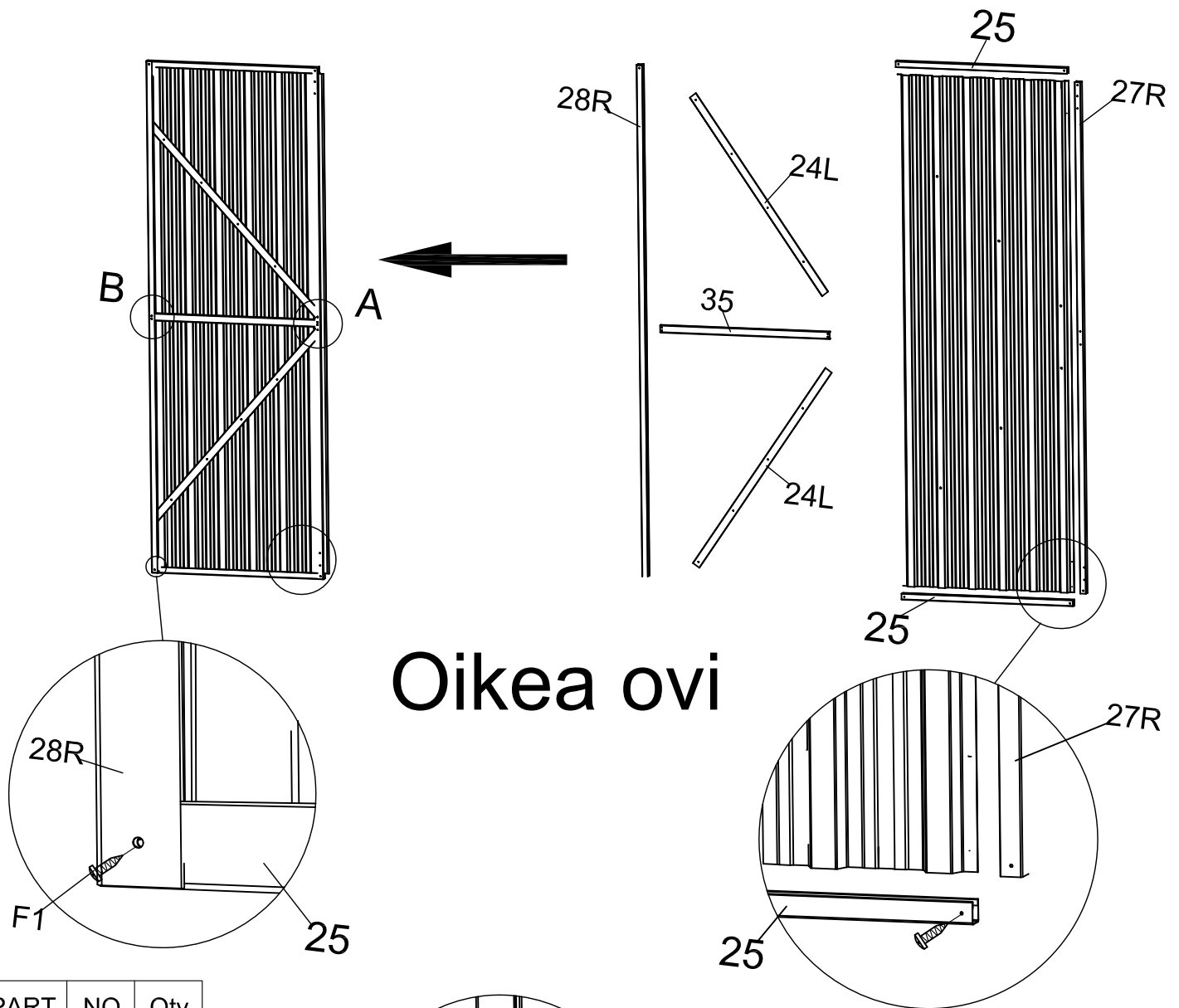

Oikea ovi

PART	NO.	Qty.
	25	2
	27R	1
	28R	1
	24L	2
	35	1
	D2	1
	D3	1
	F1	

Kiinnitä osat 25, 27R, 28R, 24R ja 35 osiin D2 ja D3 ruuveilla (F1) kuvan mukaisesti. Varmista, että kiinnität osat oven takaosaan.



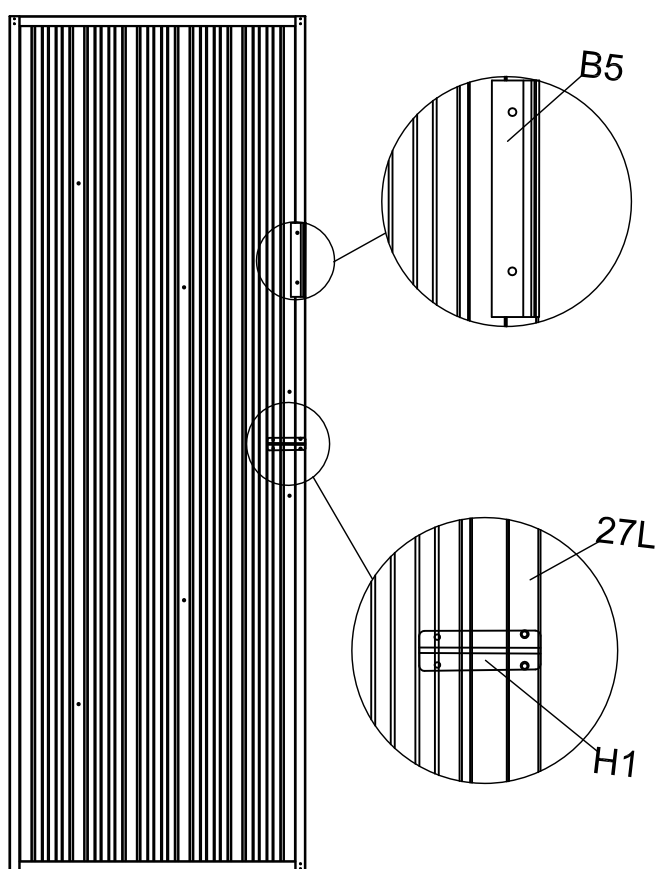

OVIENT KOKOAMINEN, OSA 3 (MALLIT SNCG-C1, C2)

Vasen ovi

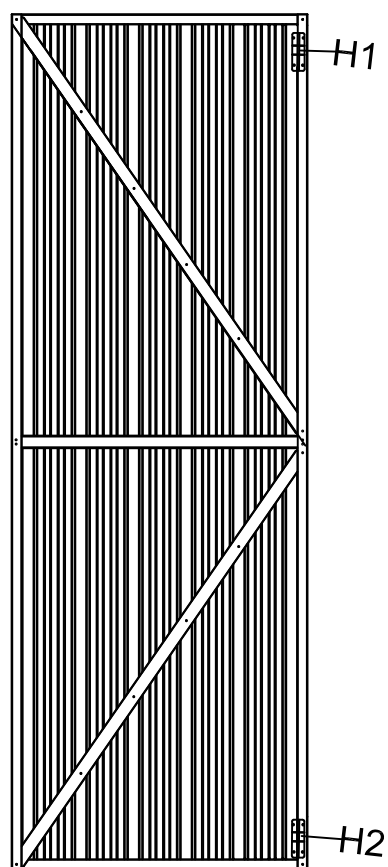

Oikea ovi



PART	NO.	Qty.
	B5	2
	H1	2
	H2	1
	F1	

Kiinnitä osat B5, H1 ja H2 ruuveilla (F1) oven etupuolelle.

OVIEN ASENNUS (MALLIT SNCG-C1, C2)

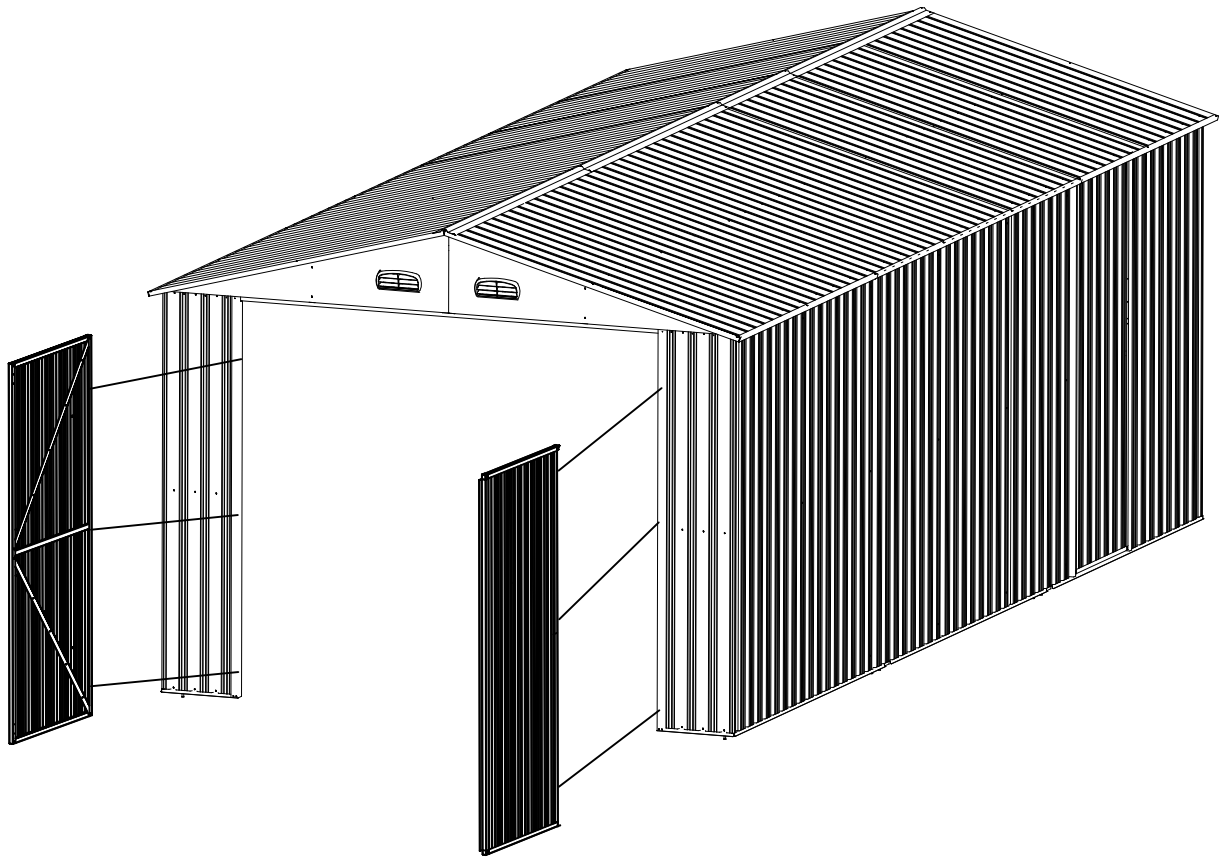

PART	NO.	Qty.
	F7	

Kiinnitä ovi osiin 5L ja 5R osalla B6.

VARMISTA TALLIN TURVALLISUUS

On tärkeää varmistaa, että harkot tai betonilaatat tukevat tallia riittävästi ja kestävät tuulen kuorman. Älä ankkuroi tallia suoraan asfalttiin.

Varoitus: Valmistaja ei ole vastuussa henkilö- tai omaisuusvahingoista, jotka johtuvat riittämättömästä ankkuroinnista riippumatta siitä, onko tallin asentanut valmistaja, sen edustaja tai muu henkilö.

HOITO JA YLLÄPITO

Pintakäsittely: Pitkäikäisen pintakäsittelyn saat puhdistamalla ja vahaamalla ulkopinnat säännöllisesti. Korjaa naarmut heti, kun huomaat niitä. Harjaa alue välittömästi teräsharjalla. Pese ja maalaa harjattu kohta.

Katto: Poista lehdet ja lumi katolta pitkällä ja pehmeällä harjalla. Suuret lumikuormat voivat vaurioittaa tallia tehden siitä vaarallisen.

Ovet: Pidä ovien kiskot puhtaana, jotta ne liukuvat ongelmitta. Voitele kiskot vuosittain kalusteiden kiillotusaineella tai silikonisuihkeella. Pidä ovet kiinni välttyäksesi tuulen tekemiltä vahingoilta.

Kiinnikkeet: Käytä toimitukseen kuuluvia aluslevyjä estääksesi veden pääsyn reikiin ja suojellaksesi metalliosia ruuvien tekemiltä naarmuilta. Tarkista ruuvien, pulttien, muttereiden yms. kireys säännöllisesti. Kiristä tarvittaessa.

Kosteus: Koko lattian kokoinen muovikalvo (höyrynsulku) riittävällä ilmanvaihdolla vähentää kondensoitumista.

Muita neuvoja

Pese osanumerot pois paneeleista saippualla ja vedellä.

Saumoista voidaan tehdä vesitiiviitä silikonilla.

Älä säilytä uima-allaskemikaaleja tallissa. Syttyvät ja syövyttävät aineet on säilytettävä soveltuvissa ilmatiiviissä astioissa.