

## SPECIFICATION FOR COTCO LED LAMP

Document No: SPE/LC503TBL1-15Q-A-MT  
Model No : LC503TBL1-15Q-A-MT  
Rev. No: 01  
Date: 2006-04-18

Description:

15 Degree 5mm LED Lamp in Blue Color with  
Water Transparent Lens and No Stopper

\*This specification is only for MT  
Dice Material: InGaN

Confirmed  
by Customer: \_\_\_\_\_

Date: \_\_\_\_\_

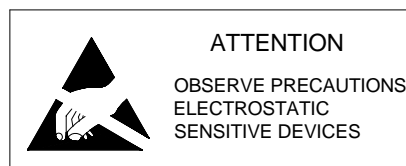

Document No.	SPE/LC503TBL1-15Q-A-MT
Rev. No.	01

**Applications:**

- Advertising Signs
- Indicators
- LCD Back Light
- Moving Message Signs

**Absolute Maximum Ratings at Ta = 25°C**

Items	Symbol	Absolute maximum Rating	Unit
Forward Current	$I_F$	25	mA
Peak Forward Current*	$I_{FP}$	100	mA
Reverse Voltage	$V_R$	5	V
Power Dissipation	$P_D$	100	mW
Operation Temperature	$T_{opr}$	-40 ~ +95	°C
Storage Temperature	$T_{stg}$	-40 ~ +100	°C
Lead Soldering Temperature	$T_{sol}$	Max.260°C for 3 sec Max. (3mm from the base of the epoxy bulb)	

**Dimension Drawing**

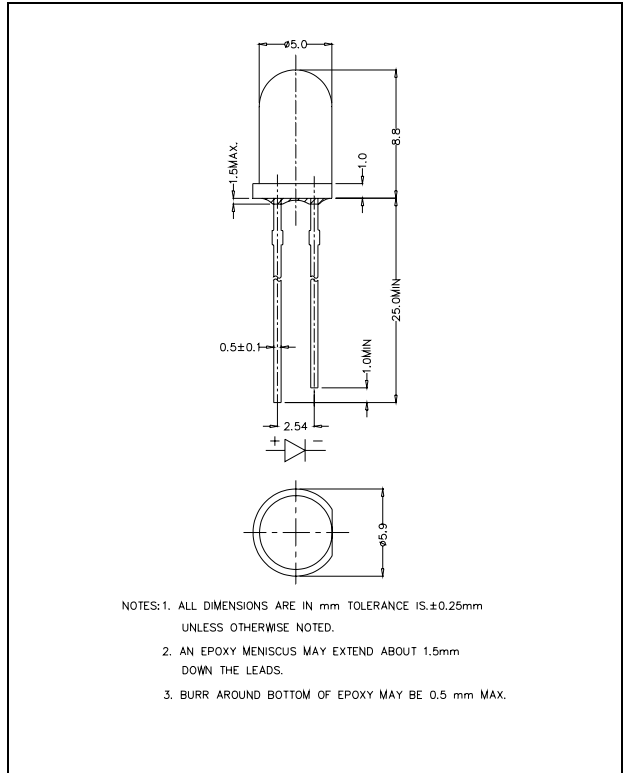

\*pulse width  $\leq 0.1$ msec duty  $\leq 1/10$

**Typical Electrical & Optical Characteristics ( Ta = 25°C)**

Items	Symbol	Condition	Min.	Typ.	Max.	Unit
Forward Voltage	$V_F$	$I_F = 20$ mA	---	3.4	4.0	V
Forward Voltage	$V_F$	$I_F = 1.0$ $\mu$ A	1.7	---	2.5	V
Reverse Current	$I_R$	$V_R = 5$ V	---	---	100	$\mu$ A
Dominant Wavelength	$\lambda_D$	$I_F = 20$ mA	465	470	475	nm
Luminous Intensity	$I_v$	$I_F = 20$ mA	4180	7000	---	mcd
50% Power Angle	20 $\frac{1}{2}$ H-H	$I_F = 20$ mA	---	15	---	deg

Rev. No.	01
----------	----

**Standard bins for LC503TBL1-15Q-A-MT ( $I_F = 20\text{mA}$ ):**

Lamps are sorted to Luminous Intensity  $-I_V$ ,  $V_F$  & Dominant Wavelength  $-\lambda_D$  bins shown.

Orders for LC503TBL1-15Q-A-MT may be filled with any or all bins contained as below.

All Luminous Intensity  $-I_V$ ,  $V_F$  & Dominant Wavelength  $-\lambda_D$  values shown and specified are at  $I_F = 20\text{mA}$ .

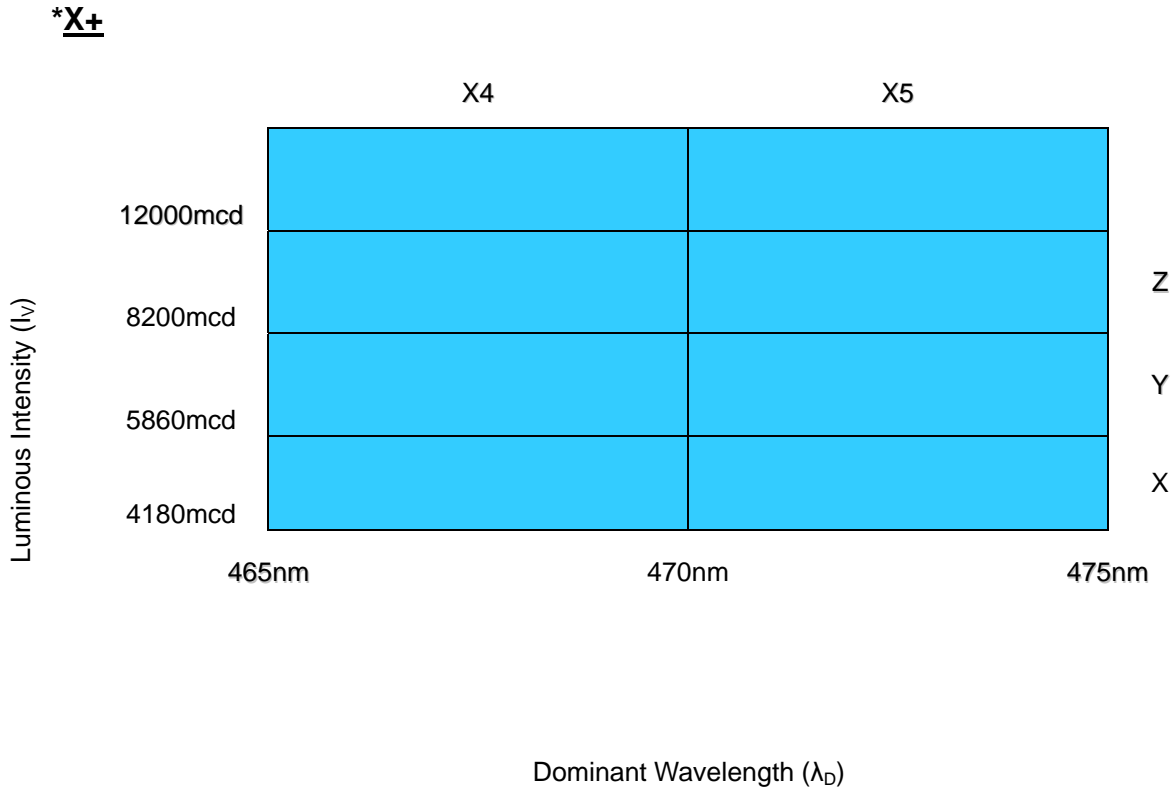

\* X+ indicates Luminous Intensity is at X bin or above.

**Forward Voltage ( $V_F$ )**

Rank	V6	V7	V8	V9	V10	V11	V12
Voltage	2.6-2.8V	2.8-3.0V	3.0-3.2V	3.2-3.4V	3.4-3.6V	3.6-3.8V	3.8-4.0V

\*Majority VF bins are highlighted in Yellow.

**Important Notes:**

- 1) All ranks will be included per delivery; rank ratio will be based on the Dices distribution.
- 2) Pb content <1000PPM.
- 3) Tolerance of measurement of luminous intensity is  $\pm 15\%$ .
- 4) Tolerance of measurement of dominant wavelength is  $\pm 1\text{nm}$ .
- 5) Tolerance of measurement of  $V_f$  is  $\pm 0.05\text{V}$ .
- 6) Packaging methods are available for selection, Please refer to PACKAGING STANDARD.
- 7) Please refer to LED LAMP RELIABILITY TEST STANDARD for reliability test conditions.
- 8) Please refer to APPLICATION NOTES for Application.

Rev. No.	01
----------	----

### Graphs

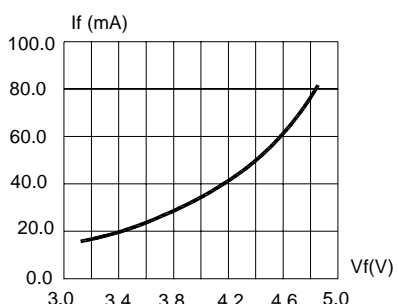

FIG.1 FORWARD CURRENT VS. FORWARD VOLTAGE.

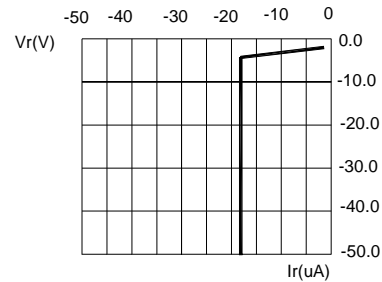

FIG.2 REVERSE CURRENT VS. REVERSE VOLTAGE.

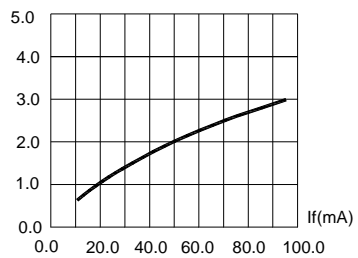

FIG.3 RELATIVE LUMINOUS INTENSITY VS. FORWARD CURRENT

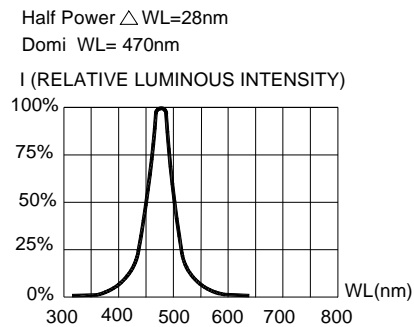

FIG.4 RELATIVE LUMINOUS INTENSITY VS. WAVELENGTH.

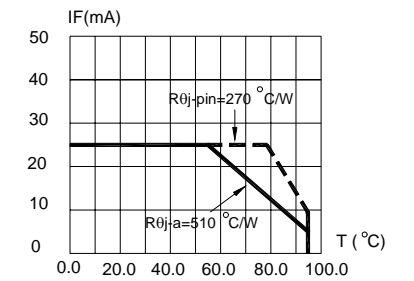

FIG.5 MAXIMUM FORWARD DC CURRENT VS. AMBIENT TEMPERATURE (Tjmax=105 °C)

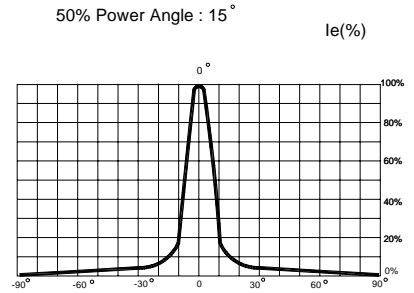

FIG.6 FAR FIELD PATTERN

1. Cathode PAD Area (0.18 X 0.18inch<sup>2</sup>)
2. Height above nominal seating plane in inches(0.3inch)

Items	Signatures	Date
Prepared by	LiuZM	2006-04-18
Checked by	Aldosin	2006-04-18
Approved by	David	2006-04-18
FCN#	FCN20060060	

Revision History		
Rev. No	Date	Change Description